



6 Qt. Combination Food Processor
Batch Bowl & Continuous Feed
FP2200

Marked for Deletion

FP2000 (on 3/28/2002)
Batch Bowl Only

FP2100 (on 4/30/2004)
Continuous Feed Only

FP2200U (on 11/10/2009)
Unipro with CAF22 & CAF26

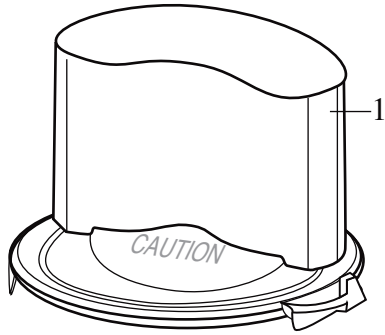

030897
13" Cleaning Brush
(on units after 3/14/2012)



030896
8.5" Cleaning Brush
(on units after 3/14/2012)

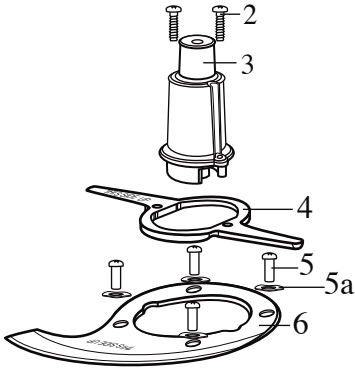

503341
S Blade Cutter Assembly
(changed after 2/8/2010)

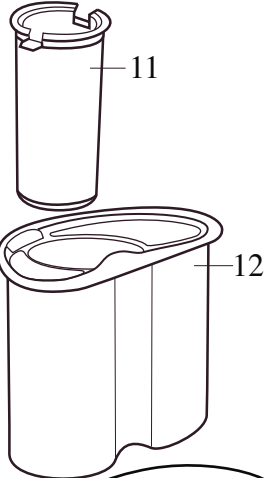

024165
1/8" Slicer (CAF12)

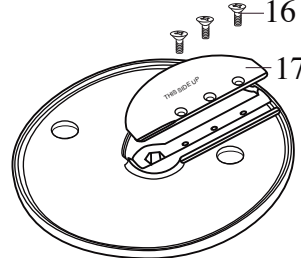

024173
3/16" Shredder (CAF20)

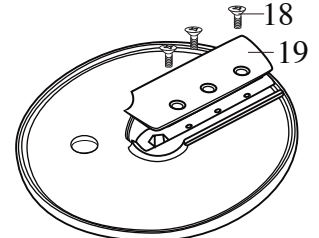

037339
(on units after 10/14/2019)
024171
1/2" Slicer (CAF18)

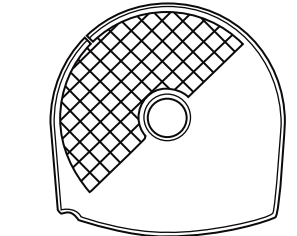
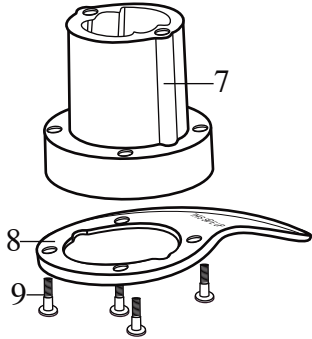

037352
(on units after 10/14/2019)
024176
1/2" Dicer (CAF24)

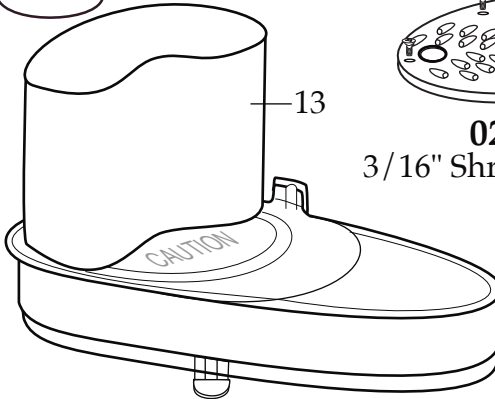

037353
(on units after 10/14/2019)
024177
3/4" Dicer (CAF25)

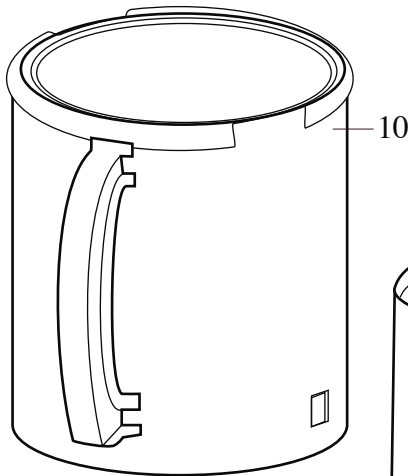

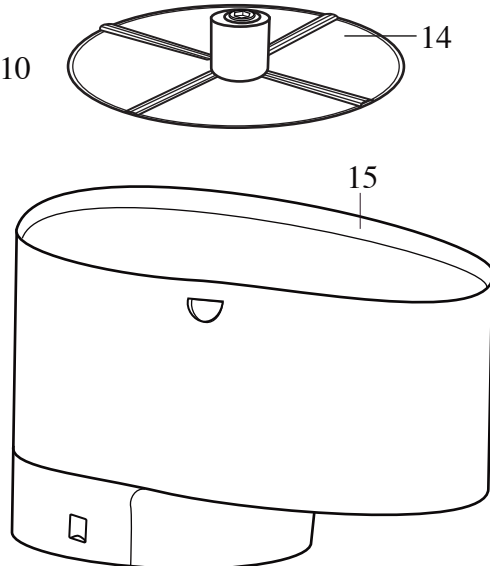

013304
NSF Seal

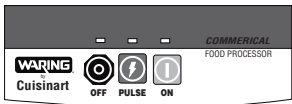

Unit Information	
60 HZ	– 12.0 Amps. – 3/4 HP
Continuous feed can process 1,400 lbs. per hour	
Warranty 5 yr. Motor	2 yr. Parts and Labor

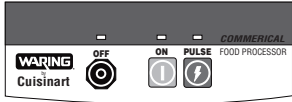

032621
Nameplate
(on units after 11/28/2012)



019573
Nameplate



Base Unit Components

FP2200

Marked for Deletion

FP2000 (on 3/28/2002)
Batch Bowl Only

FP2100 (on 4/30/2004)
Continuous Feed Only

FP2200U (on 11/10/2009)
Unipro with CAF22 & CAF26

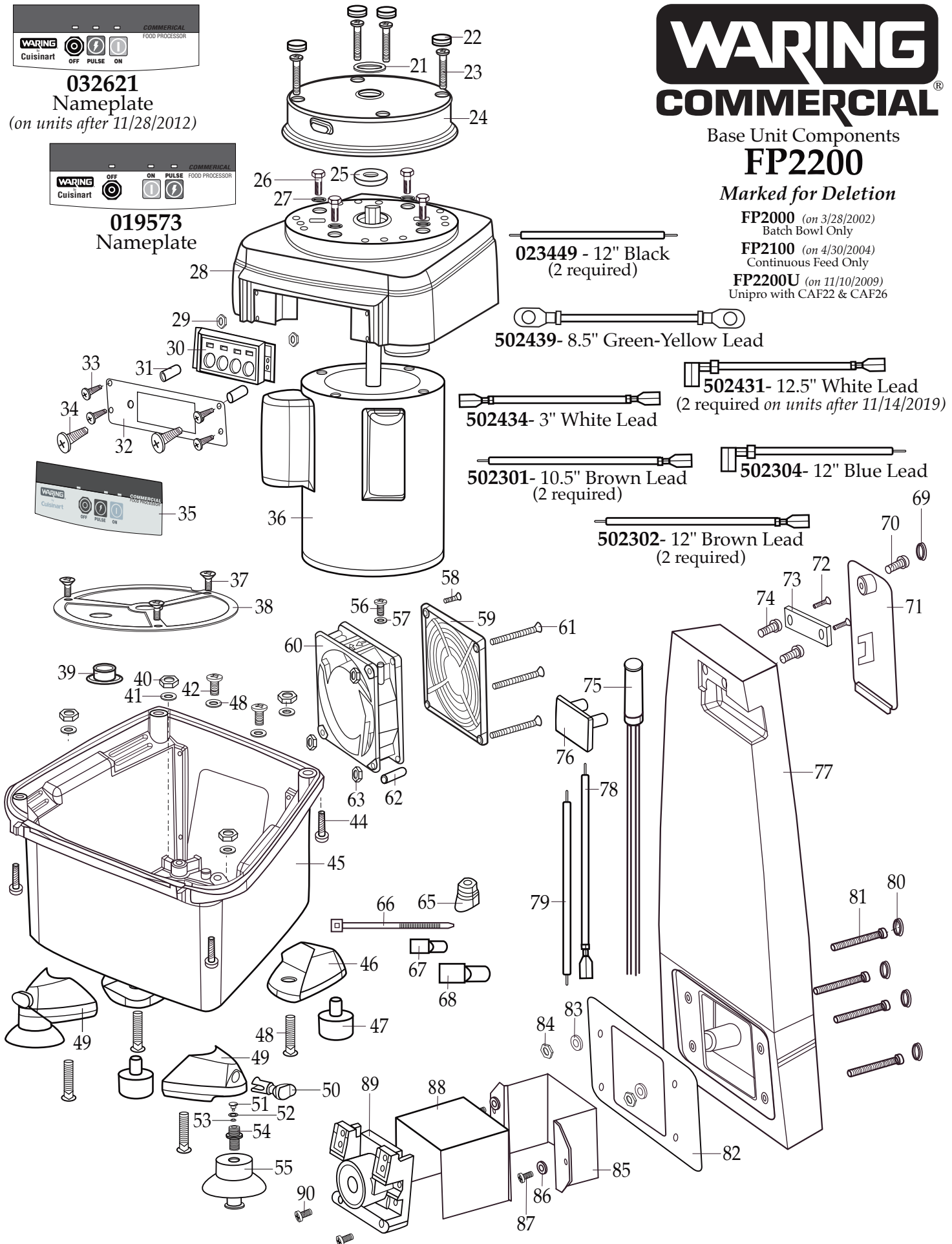

Catalog	Model
FP2200	32FP20
<i>Marked for Deletion</i>	
FP2000	32FP18
FP2100	32FP19
FP2200U	32FP20

WARING
COMMERCIAL
314 Ella T. Grasso Ave.
Torrington, CT 06790
Tele. 1-800-269-6640
Fax 860-496-9017
www.waringcommercialproducts.com

Illustration#	Part#	Description
1	502503	Batch Bowl Cover Assembly
2	024005	Screw (2 required)
3	029372 023988	Top Center Hub (<i>on units after 2/24/2009</i>) Top Center Hub (Use 503341)
4	019670	Mid Blade
5	029370 019984	Special Nut (4 required <i>on units after 2/24/2009</i>) Special Nut (4 required Use 503341)
5a	029371	Wave Washer (4 required <i>on units after 2/24/2009</i>)
6	030333 023940	Cutter Blade (<i>on units after 2/8/2010</i>) Upper Cutter Blade (use 030333)
7	029373 023989	Center Hub (<i>on units after 2/24/2009</i>) Center Hub (Use 503341)
8	030333 023940 019580	Cutter Blade (<i>on units after 2/8/2010</i>) Lower Cutter Blade (<i>on units after 2/24/2009</i> use 030333) Lower "S" Blade Cutter (Use 503341))
9	029369 023029	Special Screw (4 required <i>on units after 2/24/2009</i>) Special Screw (Use 503341)
10	019578	Batch Bowl
11	025285 024032 019834	Dark Gray Plunger Insert (<i>on units after 5/13/2004</i>) Light Gray Plunger Insert (<i>on units after 8/7/2001</i>) Clear Plunger Insert
12	025284 024033 019579	Dark Gray Plunger (kidney shape <i>on units after 5/13/2004</i>) Plunger (<i>on units after 8/7/2001</i> use 025284) White Plunger (white - half circle shape)
13	502583 502504 502293	Continuous-Feed Cover Assembly (<i>on units after 1/23/2004</i>) Continuous-Feed Cover Assembly (<i>on units after 12/3/2000</i> obsolete) Continuous-Feed Cover Assembly (use half circle plunger)
14	025286-E	Eastman Slinger Disk
15	025281	Dark Gray Continuous-Feed Bowl (<i>changed after 11/15/2000</i>)
16	019983	Flat Head Screw (3 required)
17	019689	Slicing Blade
18	023464	Flat Head Screw (3 required)
19	023055	Slicing Blade (obsolete)
20	019981	Screw (10 required)
21	018008	Washer
22	025294 019812	Dark Gray Plug (4 required <i>on units after 5/13/2004</i>) Light Gray Plug (4 required)
23	019974	Screw (4 required)
24	019566	Locking Ring

Catalog	Model
FP2200	32FP20
<i>Marked for Deletion</i>	
FP2000	32FP18
FP2100	32FP19
FP2200U	32FP20

WARING
COMMERCIAL
314 Ella T. Grasso Ave.
Torrington, CT 06790
Tele. 1-800-269-6640
Fax 860-496-9017
www.waringcommercialproducts.com

Illustration#	Part#	Description
25	018004	Seal
26	020325	Hex Bolt (4 required)
27	021082	Washer (4 required)
28	502963	Dark Gray Top Housing (<i>changed after 5/13/2004</i>)
29	001856	Kep Nut (2 required)
30	016439	Tap Touch Switch (<i>on units after 11/28/2012</i>)
	019954	Tap Touch Switch (must use with 019573 nameplate)
31	019641	Switch Spacer (2 required)
32	019572	Switch Plate
33	019096	Screw (4 required)
34	019973	Screw (2 required)
35	032621	Name Plate (<i>on units after 11/28/2012</i>)
	019573	Name Plate (use with 019574 tap touch switch)
36	019574	Motor
37	016317	Screw (3 required)
38	023233	Punched Screen
39	023211	Snap Bushing
40	023073	Nut (4 required)
41	018314	Washer (4 required)
42	017408	Screw (2 required)
43	002943	Washer (2 required)
44	019098	Screw (4 required)
45	025282	Dark Gray Bottom Housing (<i>changed after 5/13/2004</i>)
46	025292	Dark Gray Rear Foot Support (2 required <i>on units after 5/13/2004</i>)
	019968	Light Gray Rear Foot Support (2 required)
47	018790	Foot (2 required)
48	023072	Carriage Bolt (4 required)
49	502580	Dark Gray Front Foot Support Assembly (2 required <i>on units after 5/13/2004</i>)
	025293	Dark Gray Front Foot Support (2 required <i>on units after 5/13/2004</i>)
	502506	Light Gray Front Foot Support Assembly (2 required)
	024052	Light Gray Front Foot Support (2 required)
50	024037	Front Foot Actuator (2 required)
51	024039	Valve Foot Pin (2 required)
52	024040	Curved Spring Washer (2 required)
53	024042	Foot "O" Ring (2 required)
54	024038	Actuator Shaft (2 required)
55	024053	Suction Cup Foot (2 required)

Catalog	Model
FP2200	32FP20
<i>Marked for Deletion</i>	
FP2000	32FP18
FP2100	32FP19
FP2200U	32FP20

WARING
COMMERCIAL
314 Ella T. Grasso Ave.
Torrington, CT 06790
Tele. 1-800-269-6640
Fax 860-496-9017
www.waringcommercialproducts.com

Illustration#	Part#	Description
56	037717 023437	Screw <i>(on units after 6/9/2020)</i> Screw
57	002943	Washer
58	023436	Screw
59	023412 023454	Fan Guard <i>(on units after 5/13/2004)</i> Fan Guard
60	023411	Fan
61	023416	Screw (3 required)
62	002613	Insulating Sleeve
63	001856	Kep Nut (3 required)
64	014236	Cord Set
65	018811	Strain Relief
66	013731	Cable Tie (4 required)
67	012409	Small Crimp Connector (2 required)
68	019123	Large Crimp Connector (3 required)
69	025294 019812	Dark Gray Plug <i>(on units after 5/13/2004)</i> Light Gray Plug
70	019978	Screw
71	025288 019055	Dark Gray Back Plate <i>(on units after 5/13/2004)</i> Light Gray Back Plate
72	019980	Screw (2 required)
73	019979	Clamp Sensor
74	019977	Screw (2 required)
75	021741	Sensor
76	025289 019562	Dark Gray Insert <i>(on units after 5/13/2004)</i> Light Gray Insert
77	025287 502578	Tower Dark Gray Tower Assembly
78	502306	10" Blue Lead
79	023936	15.5" Black Lead
80	025294 019812	Dark Gray Plug (4 required <i>on units after 5/13/2004</i>) Light Gray Plug (4 required)
81	023325	Screw (4 required)
82	023328	Tower Gasket
83	002943	Washer (2 required)
84	016716	Hex Nut (2 required)

Catalog	Model
FP2200	32FP20
<i>Marked for Deletion</i>	
FP2000	32FP18
FP2100	32FP19
FP2200U	32FP20

WARING
COMMERCIAL
314 Ella T. Grasso Ave.
Torrington, CT 06790
Tele. 1-800-269-6640
Fax 860-496-9017
www.waringcommercialproducts.com

Illustration#	Part#	Description
85	023326	Relay Bracket
86	002943	Washer (2 required)
87	016690	Screw (2 required)
88	023360	Splash Guard
89	019569	Relay
90	023347	Screw (2 required)

Parts No Longer Used

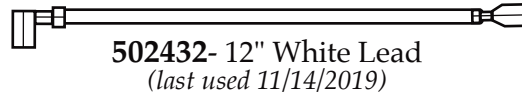
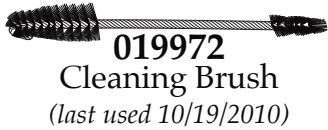

Catalog Model
FP2200 32FP20
Marked for Deletion
 FP2000 32FP18
 FP2100 32FP19
 FP2200U 32FP20

WARING COMMERCIAL
 314 Ella T. Grasso Ave.
 Torrington, CT 06790
 Tele. 1-800-269-6640
 Fax 860-496-9017
 www.waringcommercialproducts.com

Wiring Diagram

