



# MX1100XTS

## Hi-Power Electronic Keypad Blender with Timer and 64 oz. Stainless Steel Container



### MAIN FEATURES

- Heavy-duty, 3.5 peak HP, high-performance motor with 2 speed selections is the strongest in its class. It powers through the toughest ice and frozen fruit mixtures in seconds.
- Super-high, 30,000+ RPM motor speed for the smoothest consistencies.
- Premium, stainless steel container with 64 oz. capacity and cloverleaf jar design creates a high-power vortex, funneling food directly into the blade. Unbreakable and dishwasher-safe.
- High-grade, high-impact, stainless steel blade is user replaceable for servicing.
- Easy-to-clean electronic keypad with HIGH, LOW, STOP, ON/OFF, and PULSE controls and 30-second countdown timer.
- User-replaceable, metal-on-metal, stainless steel coupling system for durability and reliability.
- Easily removable container cover with removable clear cap lets you add ingredients and reduce pressure during hot food blending.
- Optional sound enclosure easily retrofits to base for noise reduction.
- Recommended for 75+ cycles per day.
- Limited Three-Year Motor and Two-Year Parts & Labor Warranty.

\*Made in USA with US and foreign parts.

### ELECTRICAL

Voltage: 120A

Frequency: 60Hz

Watts: 1560W

Amps: 12.5A

Plug Type: NEMA 5-15P

Cord Length: 6 feet



### SALES FEATURES

Get smooth, consistent results every time with the Waring® MX1100XTS. This heavy-duty 3½ peak HP blender teams up with The Raptor® jar and blade assembly for maximum power and efficiency. It's ferocious enough for everything from smoothies and frozen drinks to thick spreads, desserts, dressings and all types of food preparation. Features an easy-to-clean electronic membrane keypad with HIGH, LOW, STOP and PULSE functions, and a 30-second electronic countdown timer. Blend 75+ cycles per day. Perfect for a busy bar, health facility, school or coffee shop.

Hi-Power Electronic Keypad Blender with Timer and 64 oz. Stainless Steel Container

MX1100XTS



@waringcommercial

©2022 Waring Commercial  
314 Ella T. Grasso Avenue, Torrington, CT 06790  
Tel. 800-492-7464 • Fax 860-496-9008

waringcommercialproducts.com



# Hi-Power Electronic Keypad Blender with Timer and 64 oz. Stainless Steel Container MX1100XTS

## PARTS & ACCESSORIES

- |   |  |   |  |
|---|--|---|--|
|    | <b>CAC90</b><br>64 oz. Stainless Steel Container   |    | <b>CAC95-12</b><br>64 oz. Green Copolyester Container                      |
|    | <b>CAC93X</b><br>48 oz. Copolyester Container  |    | <b>CAC95-28</b><br>64 oz. Orange Copolyester Container                     |
|    | <b>CAC93X-03</b><br>48 oz. Yellow Copolyester Container  |    | <b>CAC116</b><br>Blending Assembly Kit and Retainer Ring Kit               |
|    | <b>CAC93X-06</b><br>48 oz. Blue Copolyester Container  |    | <b>CAC119</b><br>Retainer Ring Wrench                                      |
|    | <b>CAC93X-10</b><br>48 oz. Purple Copolyester Container  |    | <b>CAC158</b><br>Blending Assembly Kit                                     |
|    | <b>CAC93X-12</b><br>48 oz. Green Copolyester Container   |    | <b>CAC159</b><br>Retainer Ring Kit   |
|   | <b>CAC93X-28</b><br>48 oz. Orange Copolyester Container  |   | <b>CAC160</b><br>Drive Coupling  |
|  | <b>CAC95</b><br>The Raptor® – Aggressive, All-Purpose, Stackable, 64 oz., BPA-Free Copolyester Container |  | <b>CAC161</b><br>Drive Coupling Removal Tool                               |
|  | <b>CAC95-03</b><br>64 oz. Yellow Copolyester Container   |  | <b>CAC169</b><br>Spatula – Custom designed for use with MX Series Blenders |
|  | <b>CAC95-06</b><br>64 oz. Blue Copolyester Container   |  | <b>SE1000</b><br>Large Sound Enclosure                                     |
|  | <b>CAC95-10</b><br>64 oz. Purple Copolyester Container   |  | <b>SE500</b><br>Small Sound Enclosure                                      |

## DIMENSIONS

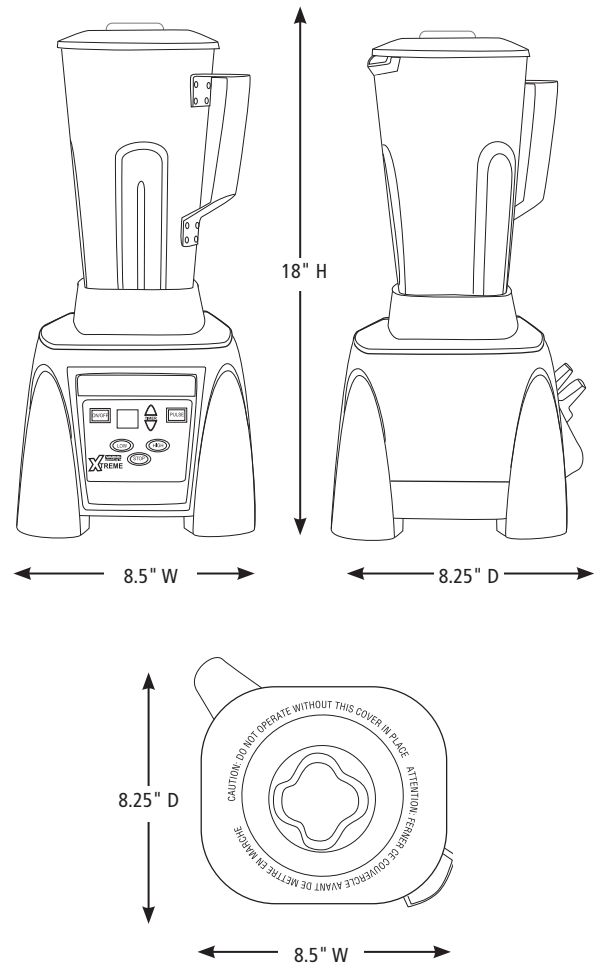

Out-of-Box Weight: 11.71 lb.

ORDERING INFORMATION	#STD. PKG.	GIFTBOX WEIGHT	CUBIC FEET	BOX DIMENSIONS D X W X H	UPC	CASE PKG.	MC WEIGHT	MC DIMENSIONS D X W X H	MBC
MX1100XTS– Hi-Power Electronic Keypad Blender with Timer and 64 oz. Stainless Steel Container	1	17.75 lb.	1.014	11.125" x 10.250" x 15.375"	040072006821	1	18.7 lb.	11.875" x 10.750" x 16.125"	10040072006828



@waringcommercial

©2022 Waring Commercial  
314 Ella T. Grasso Avenue, Torrington, CT 06790  
Tel. 800-492-7464 • Fax 860-496-9008

waringcommercialproducts.com

22WC084404 / REV 07/22