



MX1000XTS

Hi-Power Blender with 64 oz. Stainless Steel Container



*Made in USA with US and foreign parts.

ELECTRICAL

Voltage: 120V

Frequency: 60Hz

Watts: 1560W

Amps: 12.5A

Plug Type: NEMA 5-15P ⓘ

Cord Length: 6 feet



MAIN FEATURES

- Heavy-duty, 3.5 peak HP, high-performance motor with 2 speed selections is the strongest in its class. It powers through the toughest ice and frozen fruit mixtures in seconds.
- Super-high, 30,000 RPM motor speed for super-smooth consistencies.
- Simple HI, LO, OFF and PULSE paddle switches are easy to use and easy to find in dimly lit locations
- 64 oz. stainless-steel, unbreakable, dishwasher-safe container.
- High-grade, high-impact stainless steel blade is user replaceable for easy servicing.
- User-replaceable, metal-on-metal, stainless steel coupling system for durability and reliability.
- Removable, clear jar cap for adding ingredients and for pressure reduction during hot food blending.
- Optional sound enclosure easily retrofits to base for noise reduction.
- One-piece, dishwasher-safe, removable jar pad.
- Great for use in smoothie shops, coffee shops, restaurants, and bars.
- Recommended for 75+ cycles per day.
- Limited Three-Year Motor and Two-Year Parts & Labor Warranty.

SALES FEATURES

Get smooth, consistent results every time with the Waring® MX1000XTS. This heavy-duty, powerful 3½ peak HP blender teams up with our stainless steel jar/ blade assembly for maximum power and efficiency. It's ferocious enough for everything from smoothies and frozen drinks to thick spreads, desserts, dressings, and all types of food preparation. Clearly marked paddle switches control HI, LOW, OFF and PULSE features. Blend 75+ cycles per day. It's perfect for a busy bar, health facility, school, or coffee shop.

Hi-Power Blender with 64 oz. Stainless Steel Container

MX1000XTS



@waringcommercial

©2022 Waring Commercial
314 Ella T. Grasso Avenue, Torrington, CT 06790
Tel. 800-492-7464 • Fax 860-496-9008

waringcommercialproducts.com



Hi-Power Blender with 64 oz. Stainless Steel Container MX1000XTS

PARTS & ACCESSORIES

- | | | | |
|---|--|---|--|
|  | CAC90
64 oz. Stainless-Steel Container |  | CAC95-12
64 oz. Green Copolyester Container |
|  | CAC93X
48 oz. Copolyester Container |  | CAC95-28
64 oz. Orange Copolyester Container |
|  | CAC93X-03
48 oz. Yellow Copolyester Container |  | CAC116
Blending Assembly Kit and Retainer Ring Kit |
|  | CAC93X-06
48 oz. Blue Copolyester Container |  | CAC119
Retainer Ring Wrench |
|  | CAC93X-10
48 oz. Purple Copolyester Container |  | CAC158
Blending Assembly Kit |
|  | CAC93X-12
48 oz. Green Copolyester Container |  | CAC159
Retainer Ring Kit |
|  | CAC93X-28
48 oz. Orange Copolyester Container |  | CAC160
Drive Coupling |
|  | CAC95
The Raptor® – Aggressive, All-Purpose, Stackable, 64 oz., BPA-Free Copolyester Container |  | CAC161
Drive Coupling Removal Tool |
|  | CAC95-03
64 oz. Yellow Copolyester Container |  | CAC169
Spatula – Custom designed for use with MX Series Blenders |
|  | CAC95-06
64 oz. Blue Copolyester Container |  | SE1000
Large Sound Enclosure |
|  | CAC95-10
64-oz. Purple Copolyester Container |  | SE500
Small Sound Enclosure |

DIMENSIONS

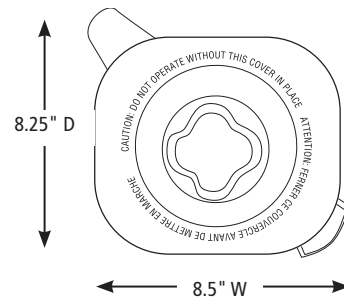
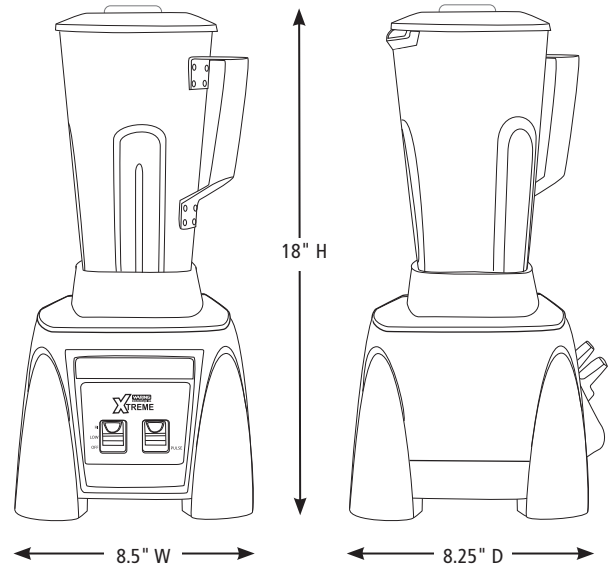

Out-of-Box Weight: 11.71 lb.

ORDERING INFORMATION	#STD. PKG.	GIFTBOX WEIGHT	CUBIC FEET	BOX DIMENSIONS D X W X H	UPC	CASE PKG.	MC WEIGHT	MC DIMENSIONS D X W X H	MBC
MX1000XTS– Hi-Power Blender with 64 oz. Stainless Steel Container	1	17.75 lb.	1.035	11.5" x 10.375" x 15.5"	040072006685	1	17.75 lb.	11.875" x 10.625" x 16.125"	10040072006682



@waringcommercial

©2022 Waring Commercial
314 Ella T. Grasso Avenue, Torrington, CT 06790
Tel. 800-492-7464 • Fax 860-496-9008

waringcommercialproducts.com

22WC084389 / REV 07/22