

WARING COMMERCIAL

Xtreme Blenders with 4 Reprogrammable Beverage Stations and a 48 oz. Stackable Container

MX1300XTXP

MX1500XTXP

comes with sound enclosure

Unit Information

Limited 3 Year Motor Warranty
Two Year Parts & Labor
60Hz – 13 Amps – 3.5 HP Motor
RPM's Maximum 30,000
Minimum 5,000
Height 21" – Weight 18 lbs.
Four Reprogrammable
One Touch Blending Stations
One Piece Dishwasher Safe
Removable Jar Pad

503351
MX Coupling Wrench
(optional)

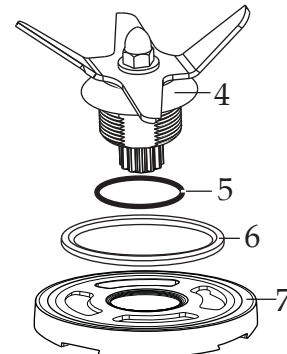
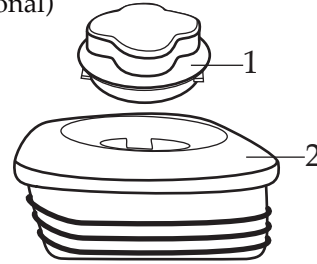

013304
NSF Seal

030889
Blending Assembly Kit

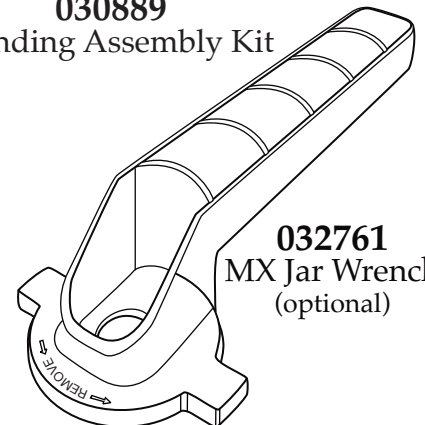

032761
MX Jar Wrench
(optional)

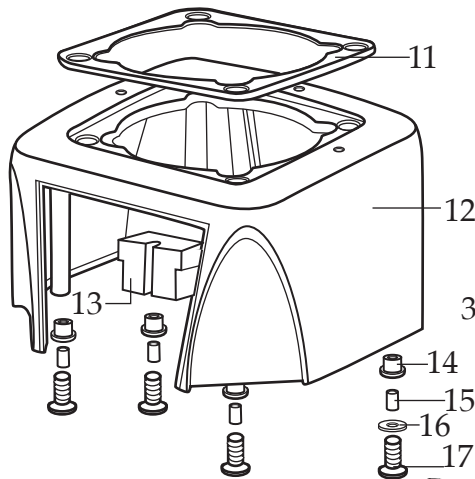
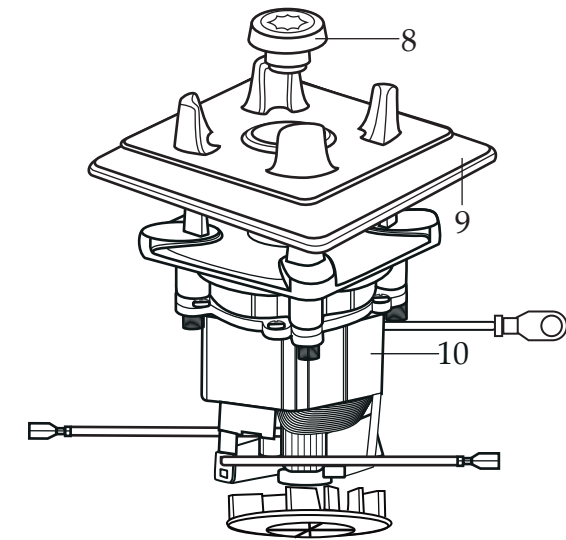

013304
NSF Seal

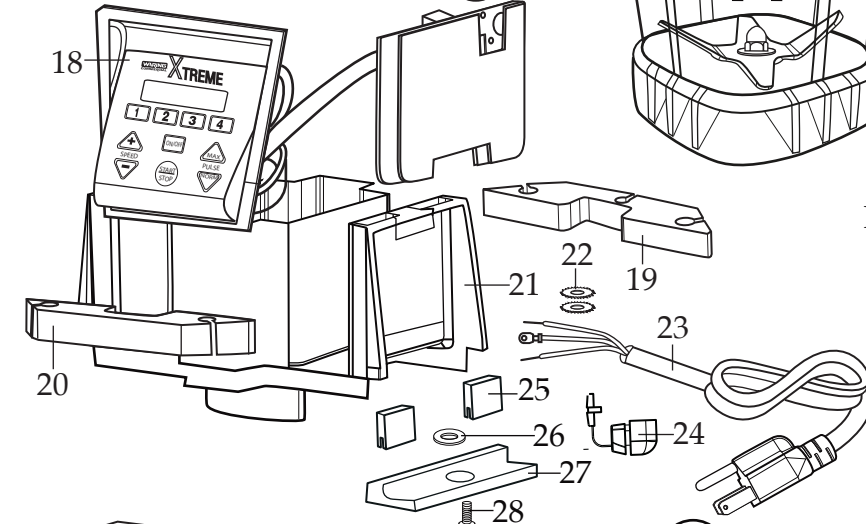

NEMA 5-15

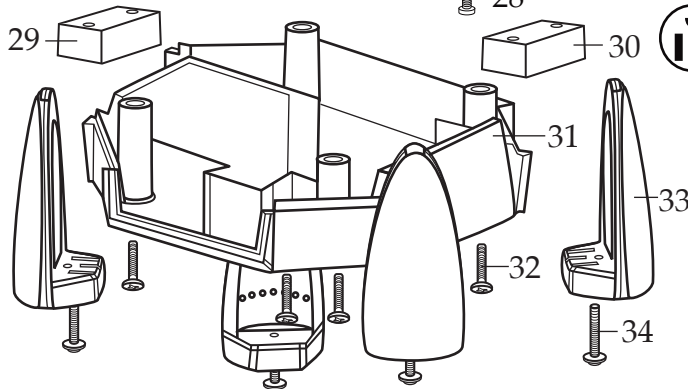

Date Code Location
YY|MM|DD
year year|month month|day day

Catalog	Model
MX1300XTXP	MX1300XT21
MX1500XTXP	MX1500XT22

WARING
COMMERCIAL
314 Ella T. Grasso Ave.
Torrington, CT 06790
Tele. 1-800-269-6640
Fax 860-496-9017
www.waringcommercialproducts.com

Illustration#	Part#	Description
1	026425-E	Jar Lid Cover
2	026424-V	Vinyl Jar Lid
3	030888	48 oz. Stackable Raptor Container ONLY
	503439	48 oz. Stackable Raptor Container with Blending Assembly
4	503397	Blade Assembly
5	024271	Bearing Holder O Ring
6	024268	Nut Gasket
7	029631	Bearing Holder Nut
8	503601	Sq. Drive Coupling with Adapter <i>(on units after 3/29/2022)</i>
	503604	Sq. Drive Coupling with Adapter 2 Gen <i>(changed after 5/7/2021)</i>
	028538	Drive Coupling
9	026442	Jar Pad (no sound enclosure)
10	035397	Leili Motor with Sensor <i>(on units after 9/1/2017)</i>
	028101	ECM Motor with Sensor
11	038278	Dampening Plate Gasket <i>(on units after 8/25/2022)</i>
	026437	Dampening Plate Gasket
12	028032-09	Top Housing /black
13	028541	Motor Foam (2 required)
14	026439	Dampening Plate Bushing (4 required)
15	038486	Dampening Plate Sleeve (4 required <i>on units after 8/25/2022</i>)
	026453	Dampening Plate Sleeve (4 required)
16	026459	Washer
17	028929	Sems (4 required)
18	036922	Control Panel with Interlock <i>(on units after 7/16/2019)</i> comes with key board-main board
	035610	Control Panel <i>(changed after 9/29/2017 use 036922)</i>
	029812	Soft Start Control Panel (use 035610)
19	028248	Top Housing Rear Foam Baffle
20	028249	Top Housing Front Foam Baffle
21	036814	Motor Housing 2.78" <i>(on units after 7/16/2019)</i>
	028240-67	Motor Housing <i>(on units after 9/1/2017)</i>
	028240	Motor Housing
22	002943	Washer (2 required)
23	026925	Cord Set
24	007556	Strain Relief
25	034900	PCB Cushions (2 required <i>on units after 7/15/2019</i>)
26	037232	Neoprene Washer <i>(on units after 7/15/2019)</i>
27	037007	PCB Mounting Bracket <i>(on units after 7/15/2019)</i>

Catalog	Model
MX1300XTXP	MX1300XT21
MX1500XTXP	MX1500XT22

WARING
COMMERCIAL
 314 Ella T. Grasso Ave.
 Torrington, CT 06790
 Tele. 1-800-269-6640
 Fax 860-496-9017
 www.waringcommercialproducts.com

Illustration#	Part#	Description
28	013768	Screw (on units after 7/15/2019)
29	028247	Bottom Housing Foam Baffle
30	028542	Foam Baffle
31	028241-09-X	Bottom Housing /black
32	012505	Screw (4 required)
33	026430	Corner Post (4 required)
34	028928	Sems (4 required)

