

Unit Information
 15.0 Amps. – 1800 Watts – 3.75 HP
 3 Year Limited Motor Warranty
 2 Year Limited Warranty
 Stackable Container

WARING
COMMERCIAL

One Gallon Blender
 with Plastic Container
CB15P

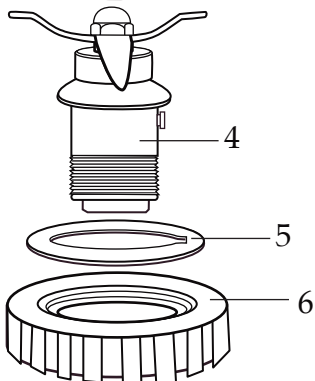
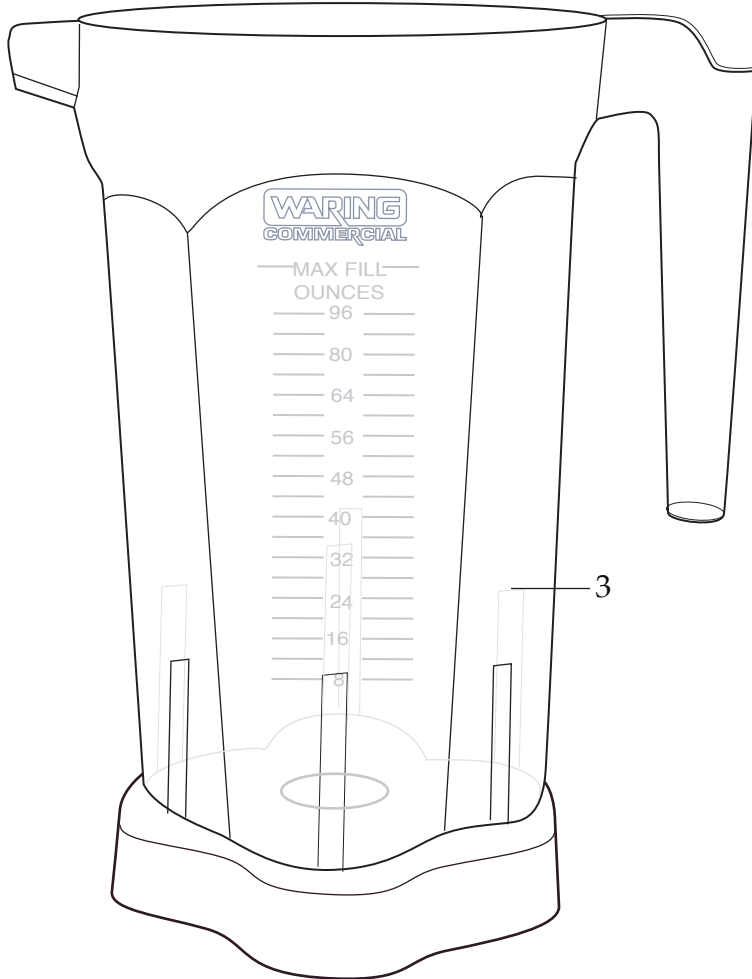

503562
 1 Gallon Plastic Container
 with Blending Assembly



013304
 NSF Seal



002963
 Wrench

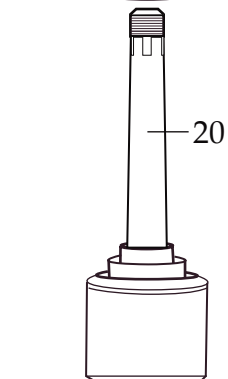
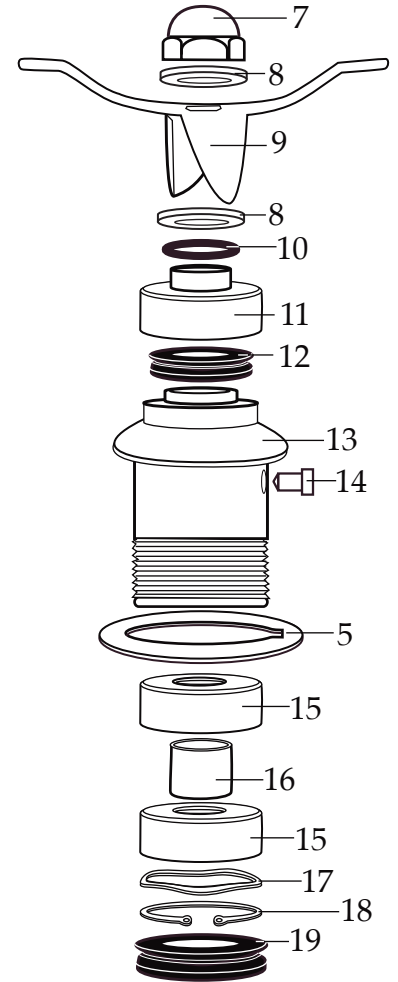

502977
 Blending Assembly

WARING COMMERCIAL®

Base Unit Components
CB15P

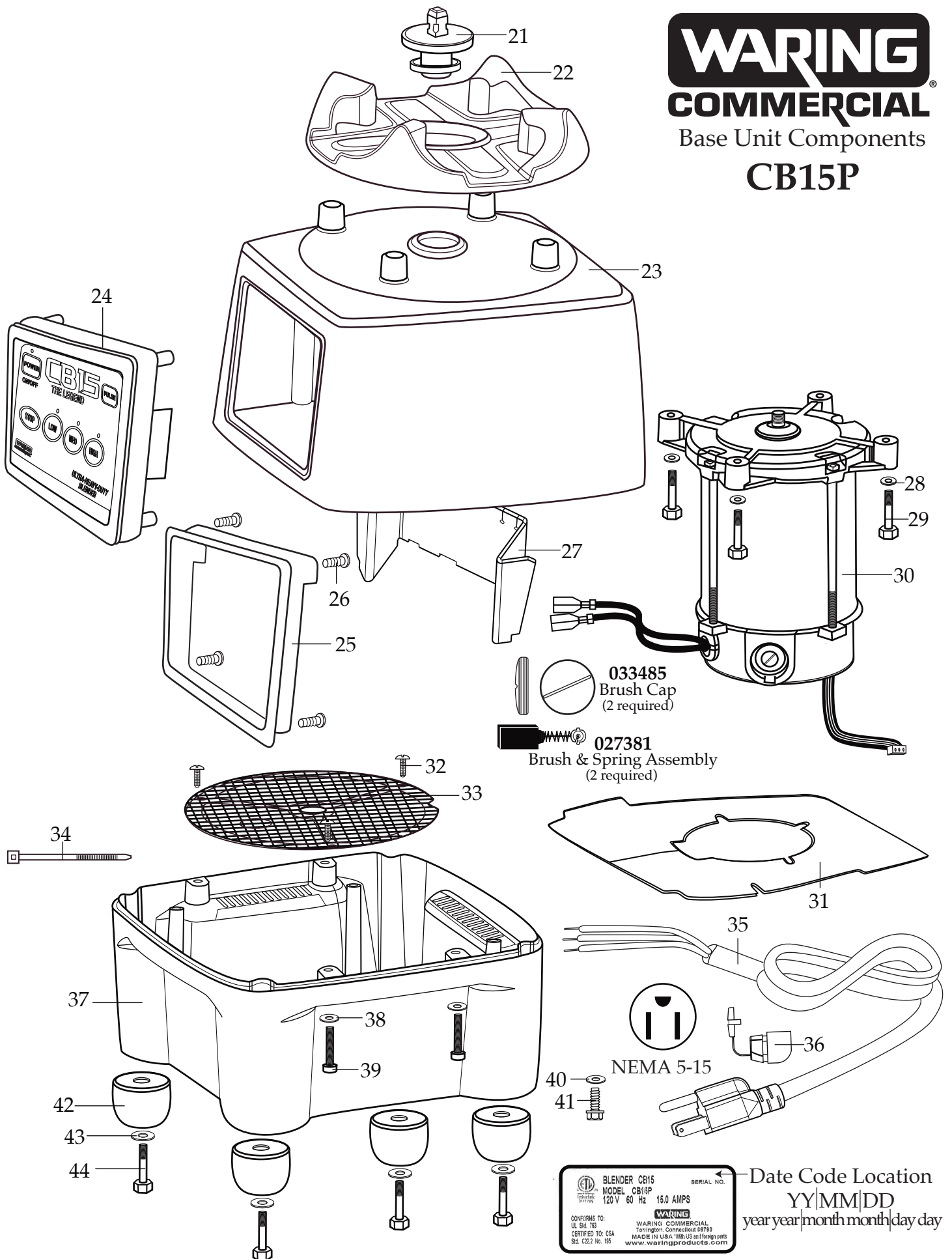

Illustration#	Part#	Description
1	028530	Jar Lid Cover
2	028226	Container Lid
3	030118	Plastic Gallon Container
4	502977	Complete Blending Assembly
5	004946	Special Washer
6	012008	Lock Nut
7	002972	Cap Nut
8	027581	Flat Washer (2 required)
9	027683	Blade
10	018389	"O" Ring
11	027582	Bearing Cap
12	018390	Small "V" Ring
13	023934	Bearing Holder
14	025817	Key
15	018386	Bearing (2 required)
16	023926	Spacer
17	023907	Spring Washer
18	023927	Retaining Ring
19	023906	Large "V" Ring
20	023933	Drive Shaft
21	503328	Coupling with Magnet Ring
22	025871	Jar Pad
23	028025	Top Housing
24	030893	Control Panel
25	029888	Rear Control Panel
26	026497	Screw (4 required)
27	030453	Control Panel Baffle
28	002984	Washer (4 required)
29	016691	Hex Bolt (4 required)
30	035520	Leili Motor
31	026318	Baffle
32	026500	Screw (6 required)

Illustration#	Part#	Description
33	018791	Screen
34	013731	Cable Tie (1 required)
35	503329	Cord Set
36	018811	Strain Relief
37	026317	Bottom Housing
38	002984	Washer (4 required)
39	026412	Screw (4 required)
40	002943	Ground Washer
41	027278	Ground Screw
42	026296	Foot (4 required)
43	018314	Washer (4 required)
44	026493	Screw (4 required)

