

WARING COMMERCIAL

Variable Speed Blender with
48 oz. Stackable Raptor Container

MX1200XTXP

Unit Information

Limited 3 Year Motor Warranty
Two Year Parts & Labor

3 HP Motor – 60Hz – 13 Amps

Height 19" – Weight 15 lbs.

RPM's Variable 1,500-20,000
Pulse 30,000

One Piece Dishwasher Safe
Removable Jar Pad

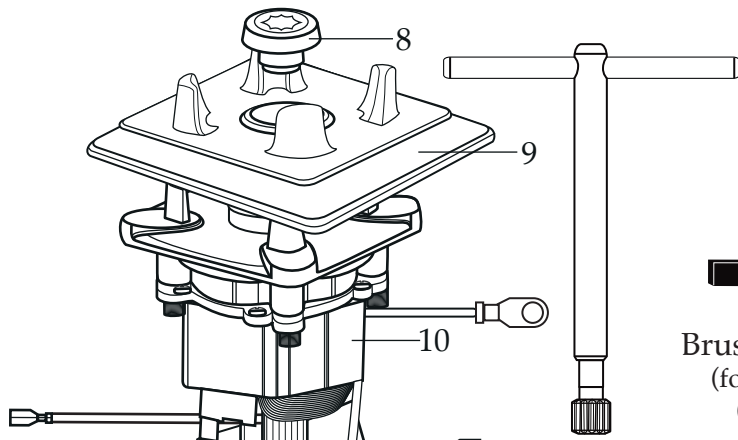

036743
Brush and Spring
(for Leili motor)
(2 required)

503351
MX Coupling Wrench
(optional)

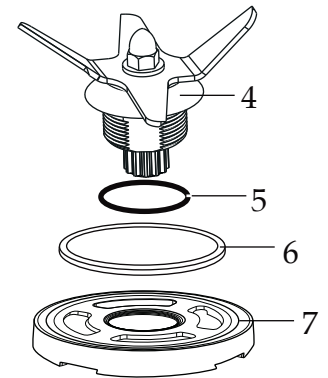
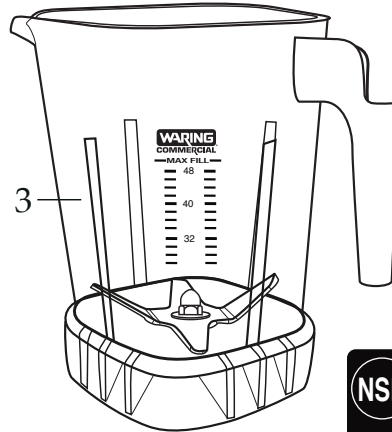
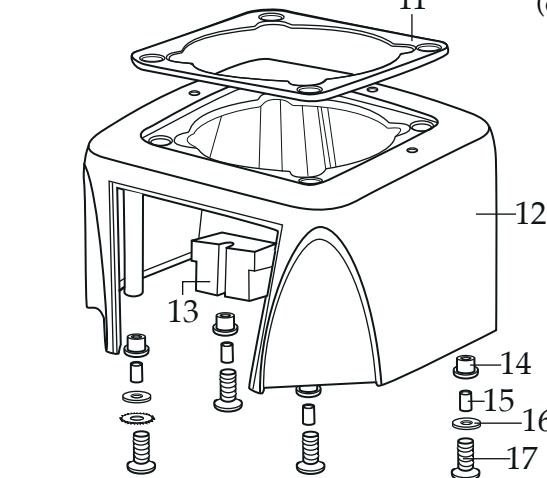
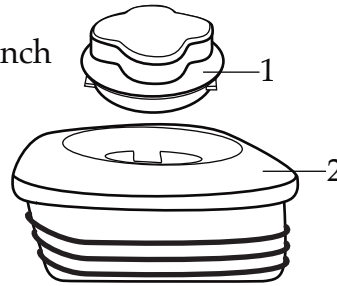

030889
Blending Assembly Kit



013304
NSF Seal

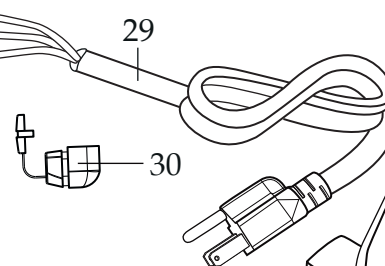
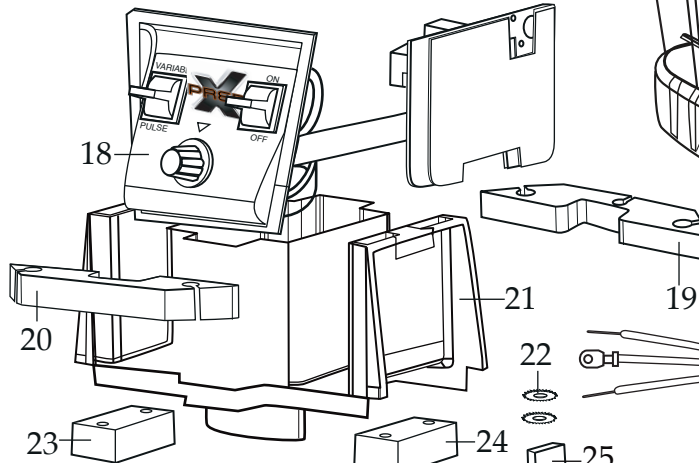

 NEMA 5-15

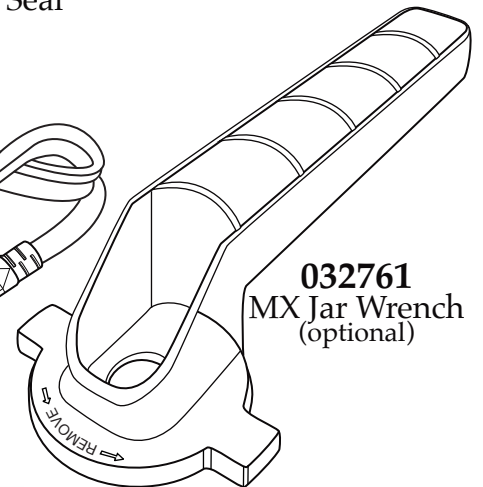

032761
MX Jar Wrench
(optional)

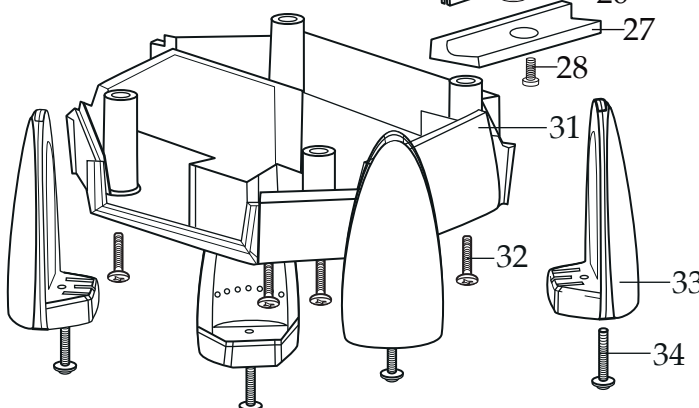

Date Code Location
YY|MM|DD
year|year|month|month|day|day

Illustration#	Part#	Description
1	026425-E	Jar Lid Cover
2	026424-V	Vinyl Jar Lid
3	030888 503439	48 oz. Stackable Raptor Container ONLY 48 oz. Stackable Raptor Container with Blending Assembly
4	503397	Blade Assembly
5	024271	Bearing Holder O Ring
6	024268	Nut Gasket
7	029631	Bearing Holder Nut
8	503601 503604 028538	Sq. Drive Coupling with Adapter <i>(on units after 3/29/2022)</i> Sq. Drive Coupling with Adapter 2 Gen. <i>(changed after 5/7/2021)</i> Drive Coupling
9	026442	Jar Pad
10	035397 028101	Leili Motor with Sensor <i>(on units after 9/1/2017)</i> ECM Motor with Sensor
11	038278 026437	Dampening Plate Gasket <i>(on units after 8/25/2022)</i> Dampening Plate Gasket
12	028032-09	Top Housing /black
13	028541	Motor Foam (2 required)
14	026439	Dampening Plate Bushing (4 required)
15	038486 026453	Dampening Plate Sleeve (4 required <i>on units after 8/25/2022</i>) Dampening Plate Sleeve (4 required)
16	026459	Washer (2 required)
17	028929	Sems (4 required)
18	036400 035013 034122	Control Panel with Interlock <i>(on units after 9/4/2018)</i> comes with switches-key board-main board Microprocessor Control Panel <i>(changed after 5/18/2015)</i> Soft Start Control Panel (use 035013)
19	028248	Top Housing Foam Rear Baffle
20	028249	Top Housing Foam Front Baffle
21	036814 028240-67 028240	2.78" Motor Housing <i>(on units after 7/19/2019)</i> Motor Housing-67 mm <i>(on units after 9/1/2017)</i> Motor Housing
22	002943	Washer (3 required)
23	028247	Bottom Housing Foam Baffle
24	028542	Foam Baffle
25	034900	PCB Cushions (2 required <i>on units after 7/19/2019</i>)
26	037232	Neoprene Washer <i>(on units after 7/19/2019)</i>

Illustration#	Part#	Description
27	037007	PCB Mounting Bracket <i>(on units after 7/19/2019)</i>
28	013768	Screw <i>(on units after 7/19/2019)</i> 29 026925 Cord Set
30	007556	Strain Relief
31	028241-09-X	Bottom Housing /black
32	012505	Screw (4 required)
33	026430	Corner Post (4 required)
34	028928	Sems (4 required)

