

# Unit Information

2700 Watts – 13 Amps  
 Output - 1000+ Slices Per Hour  
 2" Opening Accommodates Thick Bread and Bagels  
 Less than 4-Minute Heat-Up Time

# WARING COMMERCIAL® 208 Volt Conveyor Toaster CTS1000B

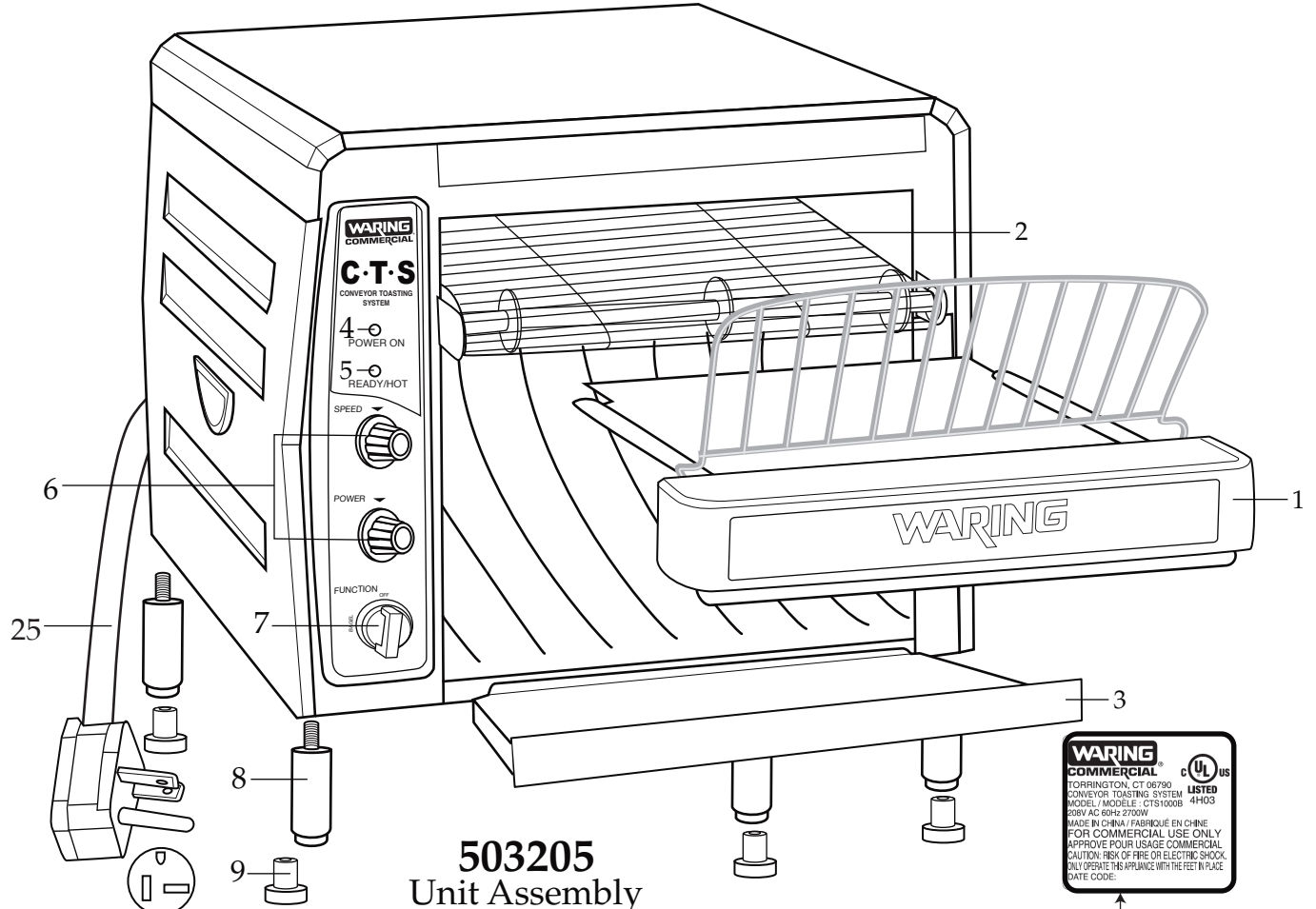

**503205**  
 Unit Assembly

**WARING COMMERCIAL**

TORRINGTON, CT 06790  
 CONVEYOR TOASTING SYSTEM  
 MODEL / MODELE: CTS1000B 4H03  
 208V AC 60Hz 2700W  
 MADE IN CHINA / FABRIQUE EN CHINE  
 FOR COMMERCIAL USE ONLY  
 APPROVE POUR USAGE COMMERCIAL  
 CAUTION: RISK OF FIRE OR ELECTRIC SHOCK  
 ONLY OPERATE THIS APPLIANCE WITH THE FEET IN PLACE  
 DATE CODE:

Date Code Location  
 YY|MM|DD  
 year year | month month | day day

## Internal Components (current)

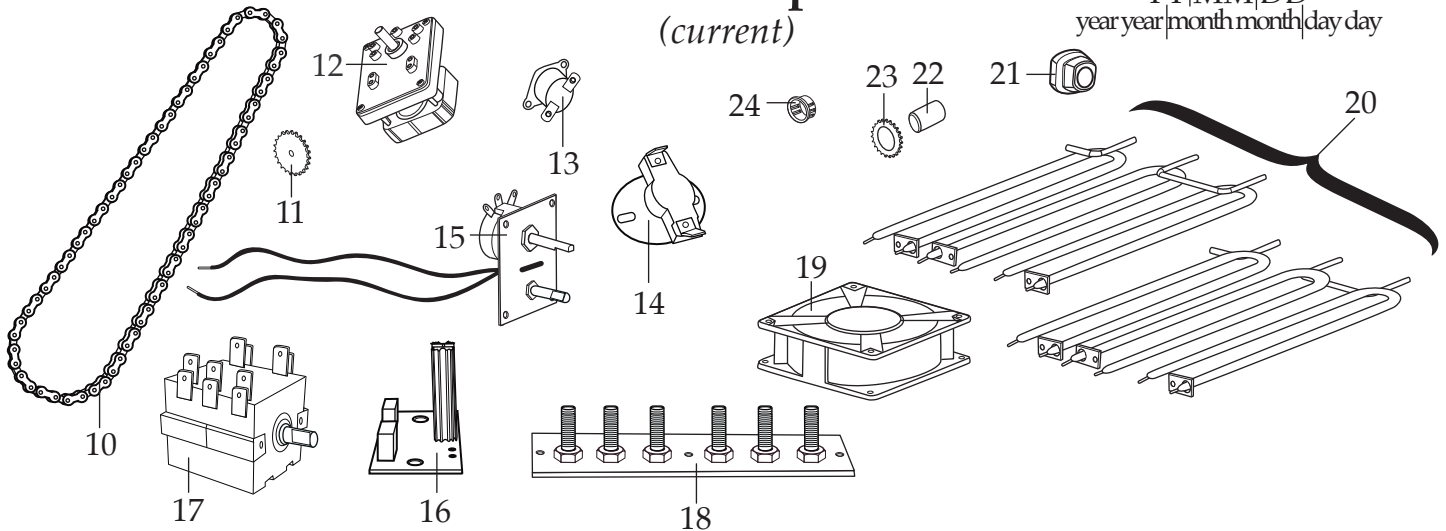

Illustration #	Part #	Description
1	028863	Crumb Tray
2	029683	Conveyor Belt
3	028864	Toaster Drawer
4	029684	Red LED Cover
5	029685	Green LED Cover
6	029105	Conveyor Speed/Power Knob (2 required)
7	033553	Function Knob
8	029687	Foot Housing (4 required)
9	028865	Foot (4 required)
10	029688	Chain
11	033556	Motor Sprocket
12	033561	AC Motor
13	032730	Thermostat (for cooling fan)
14	033559	Thermostat (for heater)
15	035180	VR PCB Assembly
16	035127	Triac
17	033558	Function Control
18	033560	Power Connection PCB Assembly
19	029698	Fan Assembly
20	029775	Heater (set of 1 upper & 1 lower)
21	029700	Cable Clamp (strain relief)
22	029695	Space Tube (2 required)
23	029694	Conveyor Sprocket
24	029691	Clamp Bushing-nylon
25	033557	Cord

### Older Unit Parts

