



WCG75

Pro Prep® Chopper-Grinder



Pro Prep® Chopper-Grinder



MAIN FEATURES

- Powerful, ¾ HP, high-speed, 2-pole induction motor runs fast and quiet. Heavy-duty design gets up to speed quickly and maintains high speed for quick and efficient grinding and chopping.
- Blades, bowls and covers are all dishwasher safe for quick and easy cleaning.
- Bowl assemblies stack on top of one another for compact storage. Stack multiple chopping and grinding bowls for quick and efficient storage in busy kitchens.
- 2 separate bowl and blade assemblies, one for grinding and another for chopping.
 - The chopping assembly consists of a ¾-quart, see-through work bowl with a 2-blade hub designed for fast and efficient chopping of foods such as garlic, shallots, onions, and leafy herbs like basil, rosemary, parsley and thyme. The chopping bowl cover has 2 protected openings that let you add ingredients with the motor running.
 - The grinding assembly is a unique, patent-pending, ¾-quart, see-through work bowl with cover, and a 3-blade hub to grind spices and hard foods, such as cheeses, chocolate, nuts, coffee beans, peppercorns, allspice, celery seed and mustard seed. The grinding bowl cover is closed on top and has a handle for a secure grip.
- Safety features protect you and the processor. Thermal overload protection guards the motor from damage due to heavy-duty loads and excessive use. The safety interlock system does not allow the processor to operate unless all parts are securely in place.
- Limited One-Year Warranty.

ELECTRICAL

Voltage: 120

Frequency: 50/60Hz

Watts: 420

Amps: 3.5

Plug Type: A

Cord Length: 5 feet



SALES FEATURES

The Waring® WCG75 Pro Prep® Chopper-Grinder is engineered for the professional kitchen to give you the right tools for specific tasks with no tainting of flavors. It's perfect for prep jobs and finishing touches. Grind spices and hard foods, such as Parmesan and Romano cheeses, hard chocolate, nuts, coffee beans, peppercorns, allspice, celery seed, mustard seed and more.



@waringcommercial

©2021 Waring Commercial
314 Ella T. Grasso Avenue, Torrington, CT 06790
Tel. 800-492-7464 • Fax 860-496-9008

waringcommercialproducts.com

WCG75



Pro Prep® Chopper-Grinder WCG75

PARTS & ACCESSORIES



WCG501TX Chopping Blade



WCG502TX Grinding Blade



WCG505TX Chopping Bowl and Chopping Cover



WCG506TX Grinding Bowl and Grinding Cover

DIMENSIONS

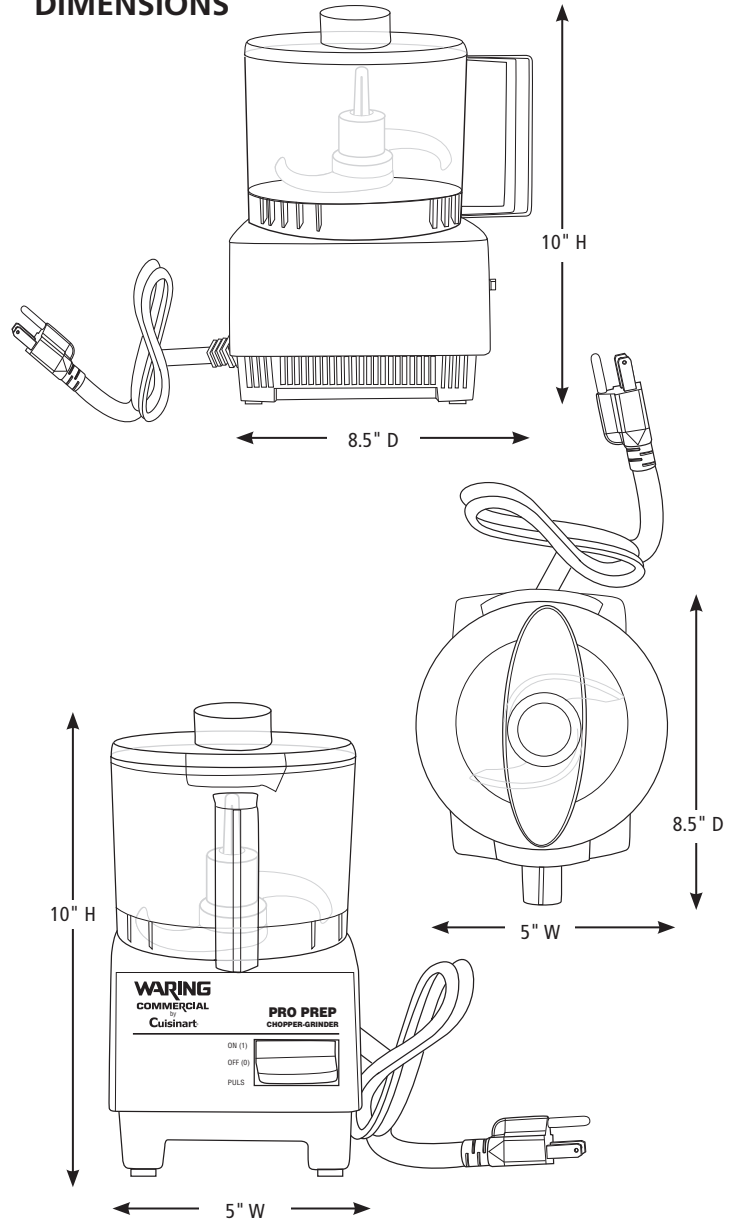

Out of Box Weight: 9.37 lb.

ORDERING INFORMATION	#STD. PKG.	GIFTBOX WEIGHT	CUBIC FEET	BOX DIMENSIONS D X W X H	UPC	CASE PKG.	MC WEIGHT	MC DIMENSIONS D X W X H	MBC
WCG75 – Pro Prep® Chopper-Grinder	1	24.5	0.64	10.875" x 6.75" x 15.125"	040072101779	1	26.2	11.375" x 7.375" x 16"	10040072101776



@waringcommercial

©2021 Waring Commercial
314 Ella T. Grasso Avenue, Torrington, CT 06790
Tel. 800-492-7464 • Fax 860-496-9008

waringcommercialproducts.com

21WC072852 / REV 08/21