



Features

- Heavy-duty 1+ HP motor to handle the heaviest mixing tasks
- Large, 7-quart stainless steel bowl with carrying handles
- 12 mixing speeds with soft start for precision mixing
- Pulse function with maximum burst of power
- Tilt-back head for easy removal of attachments
- Full die-cast housing
- Includes chef's whisk, mixing paddle, dough hook and splash guard with feed chute
- Limited Two Year Warranty

Professional 7-Quart Stand Mixer

Accessories include:

- Dough Hook
- Whisk Attachment
- Splash Guard
- Paddle



WSM7Q



Professional 7-Quart Stand Mixer WSM7Q



Specifications

Item	Electrical	Listings	Dimensions (H" x W" x D")	Warranty
WSM7Q	120 VAC, 60 Hz	cETLus, NSF	15" x 12" x 16"	Limited Two Year

Ordering Information

Description	Catalog #	Std Pkg.	Ship Wt. (Lbs.)	Cubic Feet	UPC Code
Professional 7-Quart Commercial Stand Mixer	WSM7Q	1	25	3.3	040072008177

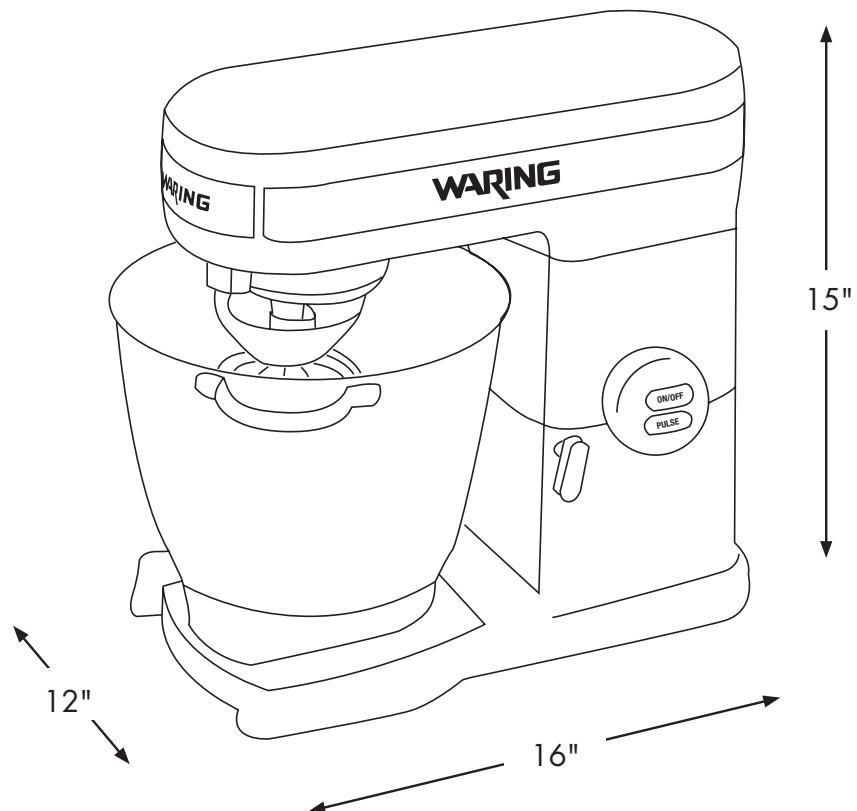

Waring Commercial • 314 Ella T. Grasso Ave. • Torrington • Connecticut 06790
Tel. (800) 492-7464 • Fax (860) 496-9008 • www.waringproducts.com • ©2007 Waring