

# WARING COMMERCIAL

Xtreme Blender with Electronic Membrane Keypad and a 30 Second Electronic Countdown Timer with a 48 oz. Stackable Raptor Container

## MX1100TXP

### Unit Information

Limited 3 Year Motor Warranty  
Two Year Parts & Labor  
60Hz - 13 Amps  
3 HP Motor - 30,000+ RPM's  
30 Second Electronic Countdown Timer  
One Piece Dishwasher Safe Removable Jar Pad



**013304**  
NSF Seal

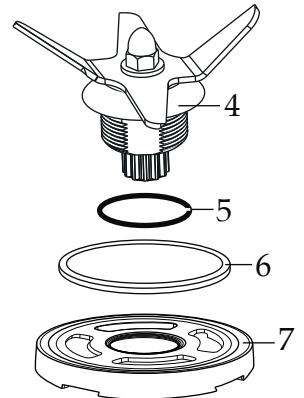

**030889**  
Blending Assembly Kit

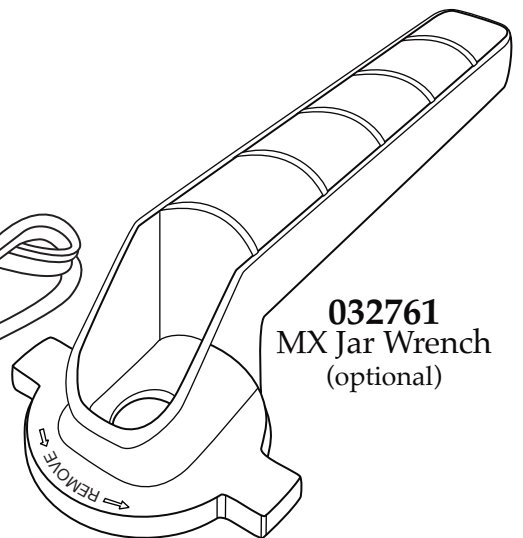

**032761**  
MX Jar Wrench (optional)



NEMA 5-15



Date Code Location  
YY|MM|DD  
year|year|month|month|day|day

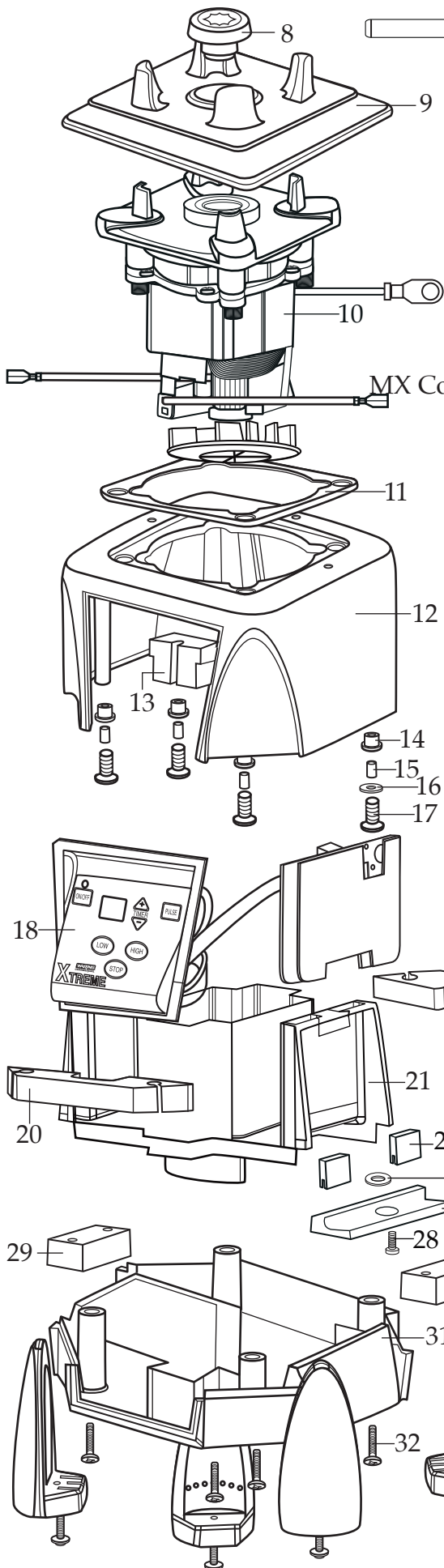

**503351**  
MX Coupling Wrench (optional)

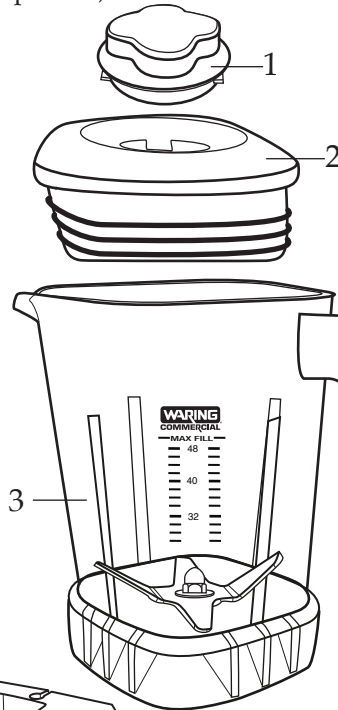

<b>Illustration#</b>	<b>Part#</b>	<b>Description</b>
1	026425-E	Eastman Jar Lid Cover
2	026424-V	Vinyl Jar Lid
3	030888	48 oz. Raptor Container ONLY
	503439	48 oz. Raptor Container with Blending Assembly
4	503397	Blade Assembly
5	024271	Bearing Holder O Ring
6	024268	Nut Gasket
7	029631	Bearing Holder Nut
8	503601	Sq. Drive Coupling with Adapter <i>(on units after 3/29/2022)</i>
	503604	Sq. Drive Coupling with Adapter 2 Gen <i>(changed after 5/7/2021)</i>
	028538	Drive Coupling
9	026442	Jar Pad
10	035396	Leili Motor without Sensor <i>(on units after 7/27/2017)</i>
	028100	ECM Motor without Sensor
11	038278	Dampening Plate Gasket <i>(on units after 8/28/2022)</i>
	026437	Dampening Plate Gasket
12	028032-09	Top Housing /black
13	028541	Motor Foam (2 required)
14	026439	Dampening Plate Bushing (4 required)
15	038486	Dampening Plate Sleeve (4 required <i>on units after 8/25/2022</i> )
	026453	Dampening Plate Sleeve (4 required)
16	026459	Washer
17	028929	Sems (4 required)
18	036398	Control Panel with Interlock <i>(on units after 8/7/2018)</i> comes with key board-main board
	029810	Soft Start Control Panel (use 036398)
19	028248	Top Housing Foam Rear Baffle
20	028249	Top Housing Foam Front Baffle
21	036814	Motor Housing 2.78" <i>(on units after 5/16/2019)</i>
	028240-67	Motor Housing 67 mm <i>(on units after 7/27/2017)</i>
	028240	Motor Housing 60 mm
22	002943	Washer (2 required)
23	026925	Cord Set
24	007556	Strain Relief
25	034900	PCB Cushion (2 required <i>on units after 5/16/2019</i> )
26	037232	Neoprene Washer <i>(on units after 5/16/2019)</i>
27	037007	PCB Mounting Bracket <i>(on units after 5/16/2019)</i>
28	013768	Screw <i>(on units after 5/16/2019)</i>
29	028247	Bottom Housing Foam Baffle

Illustration#	Part#	Description
30	028542	Foam Baffle
31	028241-09-X	Bottom Housing /black
32	012505	Screw (4 required)
33	026430	Corner Post (4 required)
34	028928	Sems (4 required)

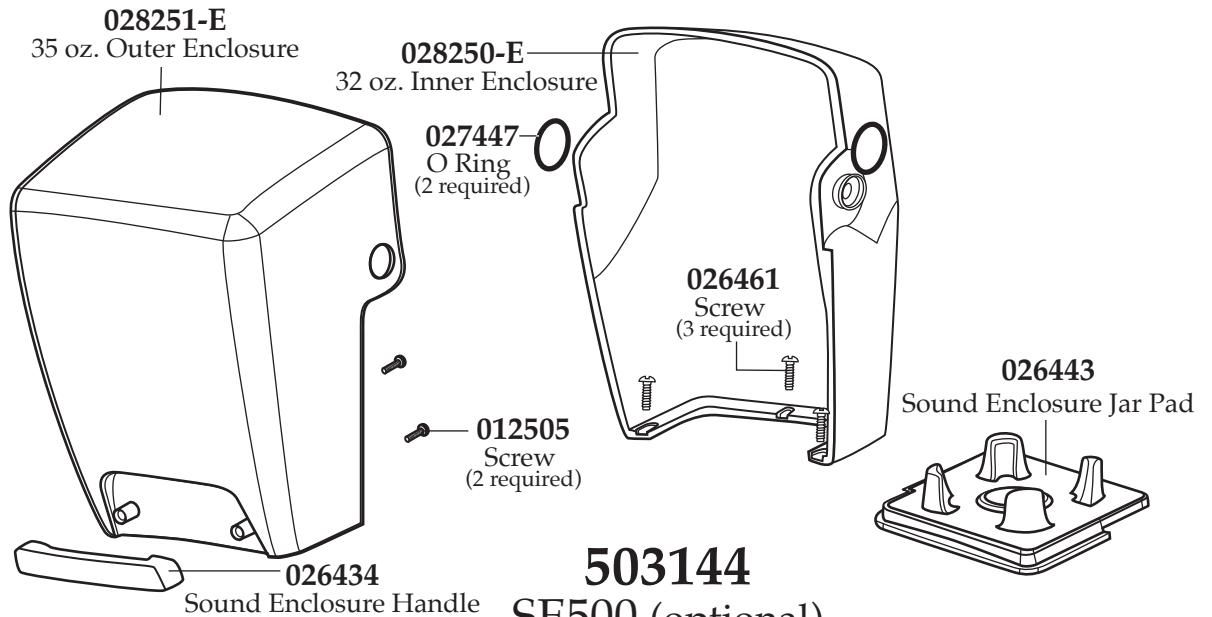

**033483**  
 Brush/Spring for ECM motor 028100  
 (2 required)



**037041**  
 Adapter

**503601**  
 Sq. Drive Coupling  
 with Adapter

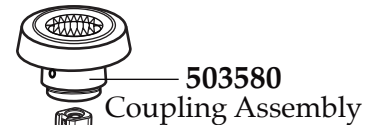

**038243**  
 Sq. Drive Adapter

**503604**  
 Sq. Drive Coupling  
 with Adapter 2 Gen.

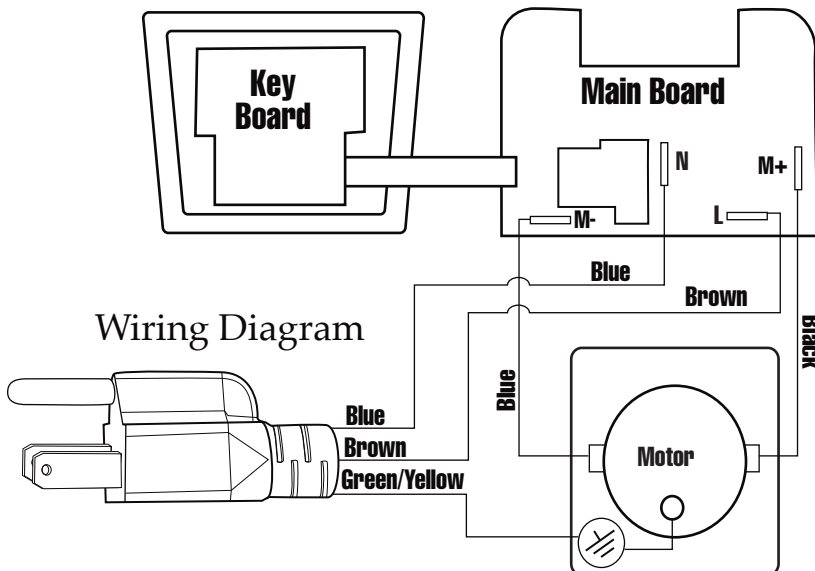

Wiring Diagram