

WARING COMMERCIAL

Xtreme Blender with Electronic Membrane Keypad and 64 oz. Raptor Container

MX1050XTX

Unit Information
Limited 3 Year Motor Warranty Two Year Parts & Labor
60Hz - 13 Amps
Height 19" - Weight 15 lbs.
3 HP Motor
30,000+ RPM's
One Piece Dishwasher Safe Removable Jar Pad

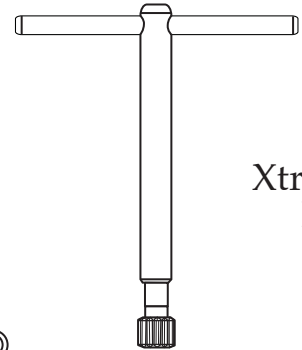
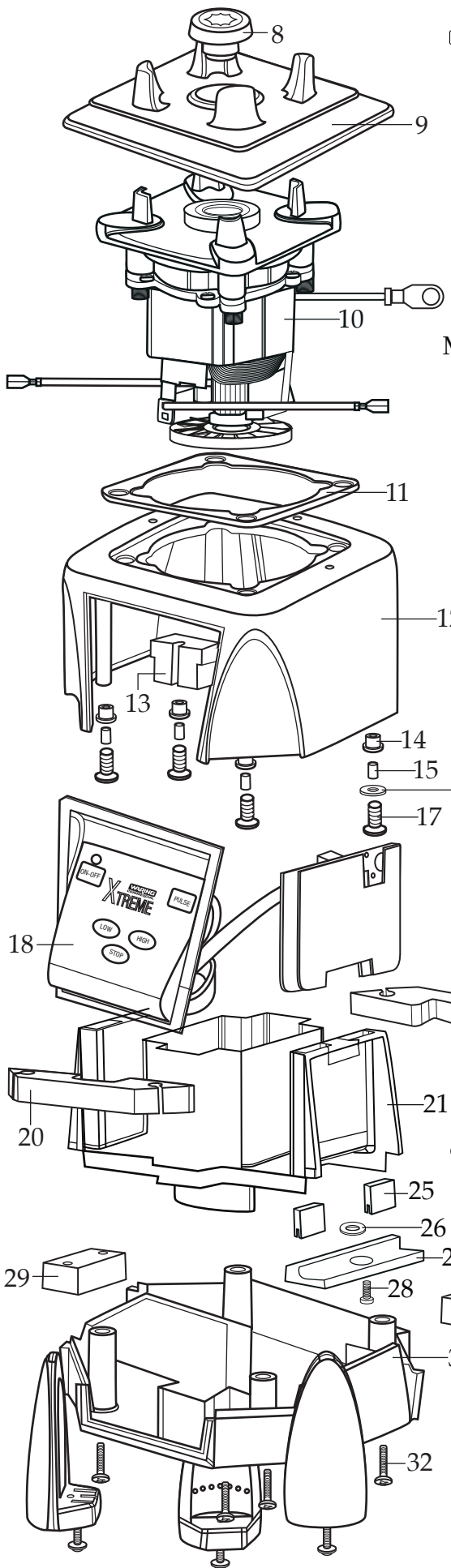

503351
MX Coupling Wrench
(optional)

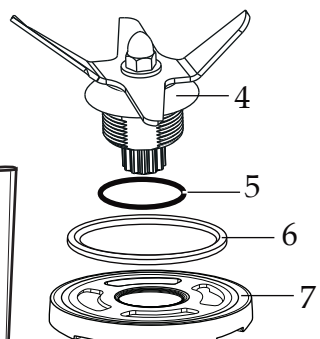
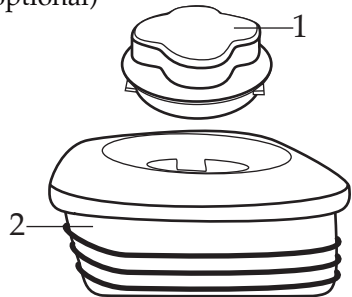

030889
Blending Assembly Kit

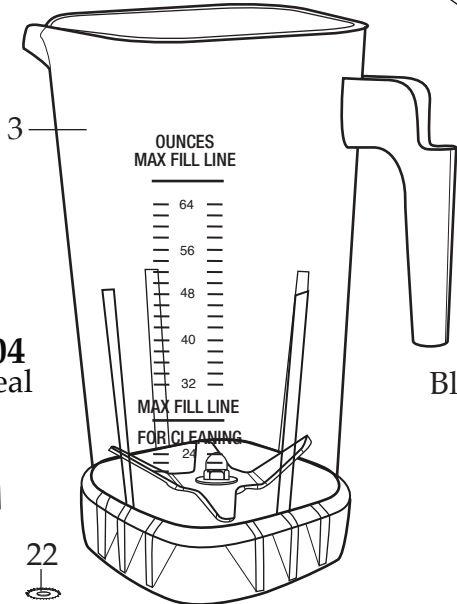

NSF
013304
NSF Seal

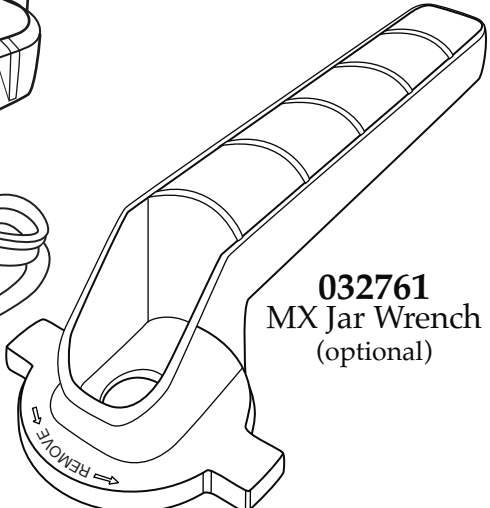

032761
MX Jar Wrench
(optional)



Date Code Location
YY|MM|DD
year year | month month | day day

Illustration#	Part#	Description
1	026425-E	Jar Lid Cover
2	026424-V	Jar Lid <i>(changed after 12/6/2012)</i>
3	503326	64 oz. Stackable Raptor Container ONLY
	503398	64 oz. Stackable Raptor Container with Blending Assembly <i>(on units after 2/17/2011)</i>
	503350	64 oz. Stackable Container with Blending Assembly
4	503397	Blade Assembly <i>(changed after 2/17/2011)</i>
5	024271	Bearing Holder O Ring
6	024268	Nut Gasket
7	029631	Bearing Holder Nut
8	503601	Sq. Drive Coupling with Adapter <i>(on units after 3/29/2022)</i>
	503604	Sq. Drive Coupling with Adapter 2 Gen. <i>(on units after 5/7/2021)</i>
	028538	Drive Coupling
9	026442	Jar Pad
10	035396	Leili Motor without Sensor <i>(on units after 7/13/2017)</i>
	028100	ECM Motor without Sensor
11	038278	Dampening Plate Gasket <i>(on units after 8/25/2022)</i>
	026437	Dampening Plate Gasket
12	028032-09	Top Housing /black
13	028541	Motor Foam (2 required)
14	026439	Dampening Plate Bushing (4 required)
15	038486	Dampening Plate Sleeve (4 required <i>on units after 8/25/2022</i>)
	026453	Dampening Plate Sleeve (4 required)
16	026459	Washer
17	028929	Sems (4 required)
18	036396	Control Panel with Interlock <i>(on units after 3/5/2019)</i> comes with key board-main board
	029809	Soft Start Control Panel (use 036396)
19	028248	Top Housing Foam Rear Baffle
20	028249	Top Housing Foam Front Baffle
21	036814	Motor Housing 2.78" <i>(on units after 7/10/2019)</i>
	028240-67	Motor Housing <i>(on units after 7/13/2017)</i>
	028240	Motor Housing
22	002943	Washer (2 required)
23	026925	Cord Set
24	007556	Strain Relief
25	034900	PCB Cushion (2 required <i>on units after 7/10/2019</i>)
26	037232	Neoprene Washer <i>(on units after 7/10/2019)</i>

Illustration#	Part#	Description
27	037007	PCB Mounting Bracket <i>(on units after 7/10/2019)</i>
28	013768	Screw <i>(on units after 7/10/2019)</i>
29	028247	Bottom Housing Foam Baffle
30	028542	Foam Baffle
31	028241-09-X	Bottom Housing /black
32	012505	Screw (4 required)
33	026430	Corner Post (4 required)
34	028928	Sems (4 required)

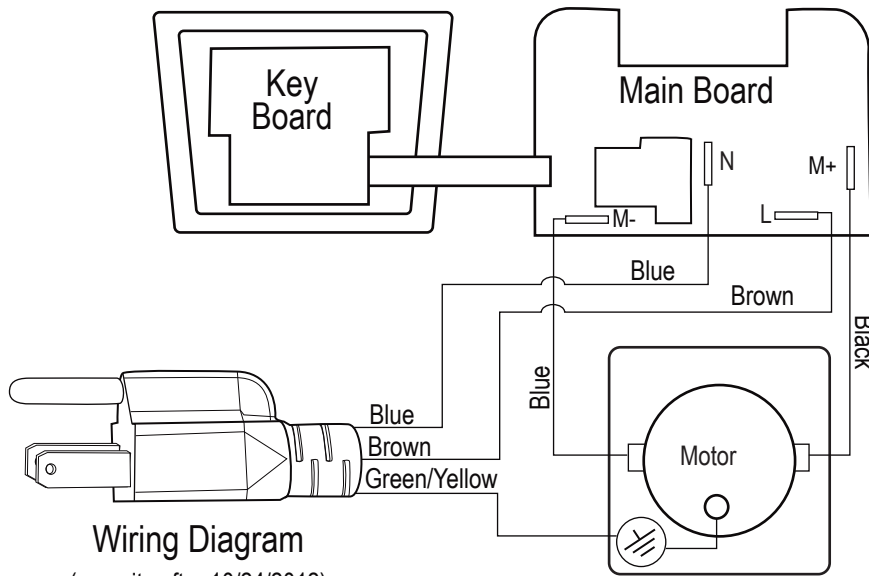

Wiring Diagram
(on units after 10/24/2012)

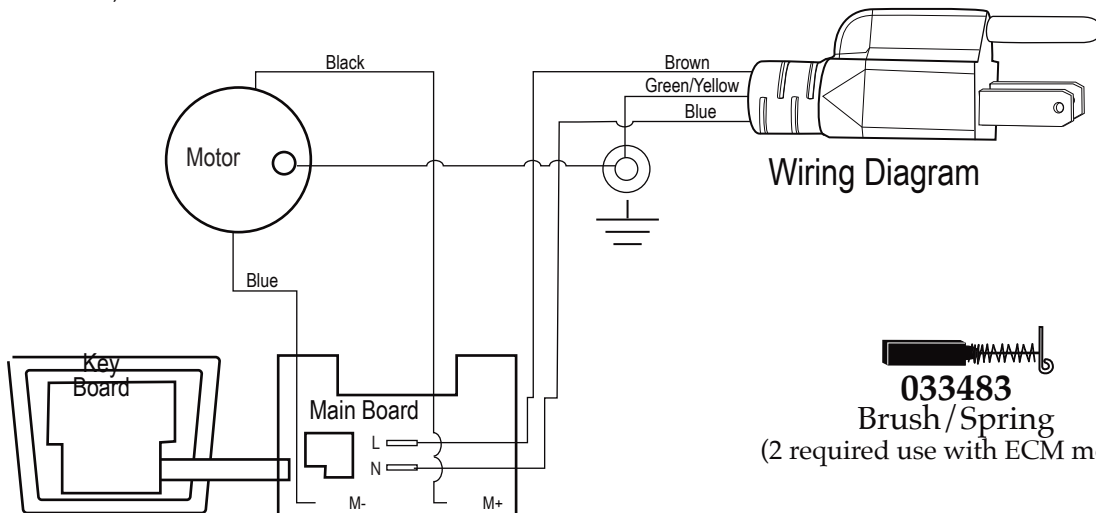

Wiring Diagram

