

WARING COMMERCIAL

Xtreme Blender with Electronic Membrane Keypad
and a 30 Second Electronic Countdown Timer with
a 64 oz. Stainless Steel Container

MX1100XTS

Unit Information

Limited 3 Year Motor Warranty
Two Year Parts & Labor
60Hz - 13 Amps
3 HP Motor - 30,000+ RPM's

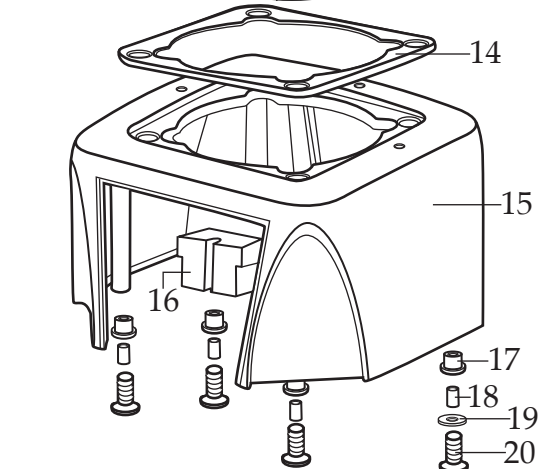
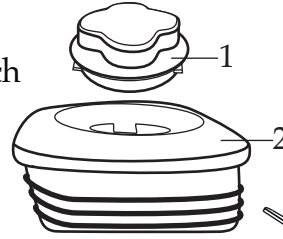
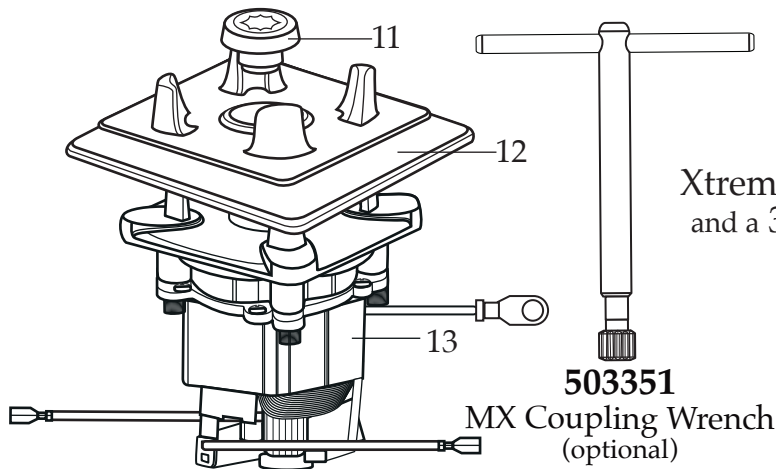

032483
Blending Assembly Kit

Notes for 503346 :

Torque 100-125 in/lbs
Lubricant applied to O Ring
Dow Corning 200 (R) Fluid

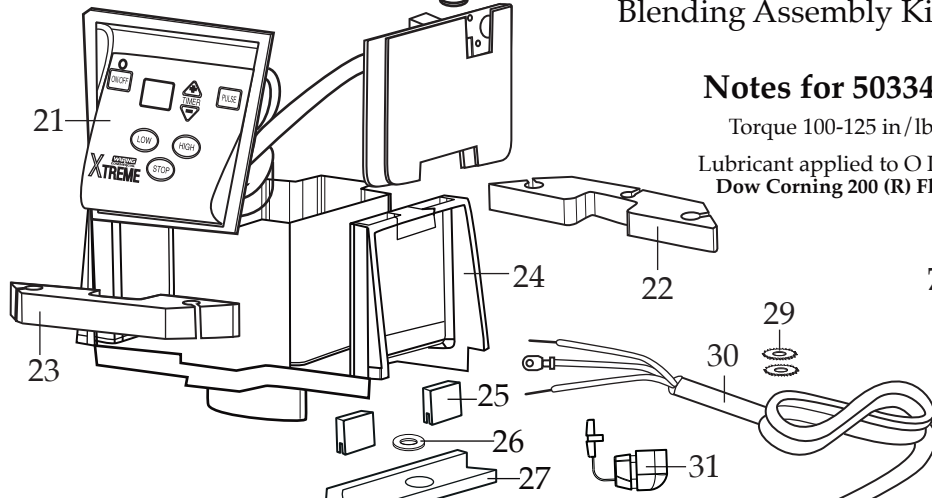
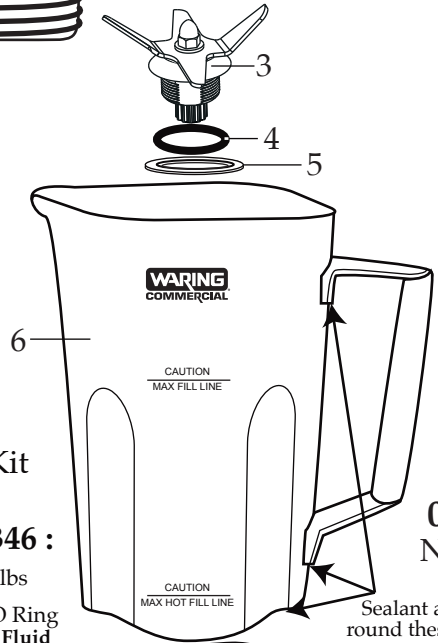

503346
Stainless Steel Container with
Blending Assembly
(on units after 2/14/2011)

503372
Stainless Steel Container with
Blending Assembly

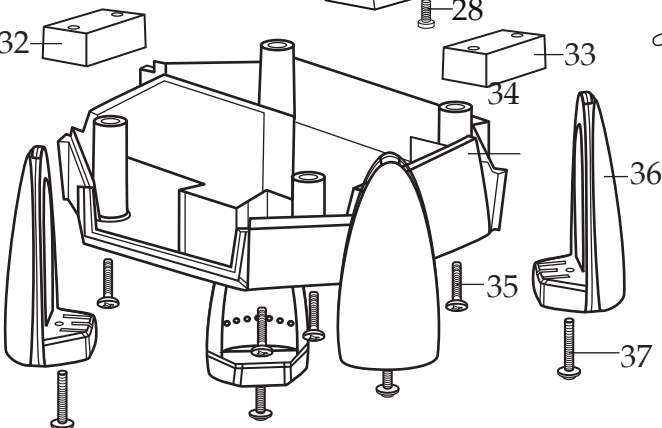

← Date Code Location
YY|MM DD
year|year|month|month|day|day

Illustration#	Part#	Description
1	026425-E	Jar Lid Cover <i>(changed after 5/26/2010)</i>
2	026424-V	Jar Lid <i>(changed after 11/20/2012)</i>
3	503566 503345	Blade Assembly <i>(on units after 2/1/2019)</i> Blade Assembly <i>(changed after 2/14/2011)</i>
4	024271	O Ring
5	026798	Support Washer
6	026648	64 oz. Stainless Steel Container ONLY
7	026649	Container Support
8	026797	Bearing Holder Gasket
9	026796	Bearing Holder Washer
10	026795	Stainless Steel Jar Bearing Holder Nut
11	503601 503604 028538	Sq. Drive Coupling with Adapter <i>(on units after 3/29/2022)</i> Sq. Drive Coupling with Adapter 2 Gen <i>(changed after 5/7/2021)</i> Drive Coupling
12	026442	Jar Pad
13	035396 028100	Leili Motor without Sensor <i>(on units after 7/27/2017)</i> ECM Motor without Sensor
14	038278 026437	Dampening Plate Gasket <i>(on units after 8/25/2022)</i> Dampening Plate Gasket
15	028032-09	Top Housing /black
16	028541	Motor Foam (2 required)
17	026439	Dampening Plate Bushing (4 required)
18	038486 026453	Dampening Plate Sleeve (4 required <i>on units after 8/15/2022</i>) Dampening Plate Sleeve (4 required)
19	026459	Washer
20	028929 026459 026455	Sems (4 required <i>on units after 6/25/2007</i>) Washer (4 required) Screw (4 required)
21	036398 029810	Control Panel with Interlock <i>(on units after 8/7/2018)</i> comes with key board-main board Soft Start Control Panel <i>(changed after 11/17/2011 use 036398)</i>
22	028248	Top Housing Foam Rear Baffle
23	028249	Top Housing Foam Front Baffle
24	036814 028240-67 028240	Motor Housing 2.78" <i>(on units after 7/18/2019)</i> 67 mm Motor Housing <i>(on units after 7/27/2017)</i> Motor Housing
25	034900	PCB Cushion (2 required <i>on units after 7/18/2019</i>)
26	037232	Neoprene Washer <i>(on units after 7/18/2019)</i>

Illustration#	Part#	Description
27	037007	PCB Mounting Bracket <i>(on units after 7/18/2019)</i>
28	013768	Screw <i>(on units after 7/18/2019)</i>
29	002943	Washer (2 required)
30	026925	Cord Set
31	007556	Strain Relief
32	028247	Bottom Housing Foam Baffle
33	028542	Foam Baffle
34	028241-09-X	Bottom Housing /blask
35	012505	Screw (4 required)
36	026430	Corner Post (4 required)
37	028928	Sems (4 required <i>on units after 6/25/2007</i>)
	026459	Washer (4 required)
	012505	Screw (4 required)

