



DMC180DCA

Wall-Mount Drink Mixer



MAIN FEATURES

- High-performance, 1 peak HP, 2-speed commercial motor
- HI/LO speed control for simple operation—runs at 24,000 RPM on HI
- Motor runs at the selected speed once the cup is in position
- Heavy-duty, die-cast metal motor housing has a classic design and won't get hot to the touch during mixing
- Fully automatic START/STOP operation ensures consistent results and frees you for other tasks
- The standard agitator powers through hard ice creams. The butterfly agitator is perfect for softer ice creams and for use with different types of cups
- Space-saving wall-mount design. Mounts onto machines or flush on walls and cabinets. Frees up counter space for larger machines and prep work
- Sealed ball bearings are lubed for life with no need to replace, providing a long service life
- Limited One Year Warranty

ELECTRICAL

Voltage: 120

Frequency: 50/60Hz

Watts: 1800

Amps: 15

Plug Type: NEMA 5-15P



SALES FEATURES

Make classic milkshakes and other mixed drinks with the Waring® DMC180DCA wall-mount drink mixer. Space-saving design mounts to machines or flush to walls and cabinets. Power through the coldest and hardest ice creams—it won't get hot to the touch during mixing. While it's running, you can be free to do other tasks.



@waringcommercial

©2020 Waring Commercial
314 Ella T. Grasso Avenue, Torrington, CT 06790
Tel. 800-492-7464 • Fax 860-496-9008

waringcommercialproducts.com

Wall-Mount Drink Mixer

DMC180DCA



Wall-Mount Drink Mixer DMC180DCA

PARTS & ACCESSORIES



CAC20 Stainless Steel Malt Cup



CAC112 Solid Agitator



CAC123 Butterfly Agitator (6 pack)

DIMENSIONS

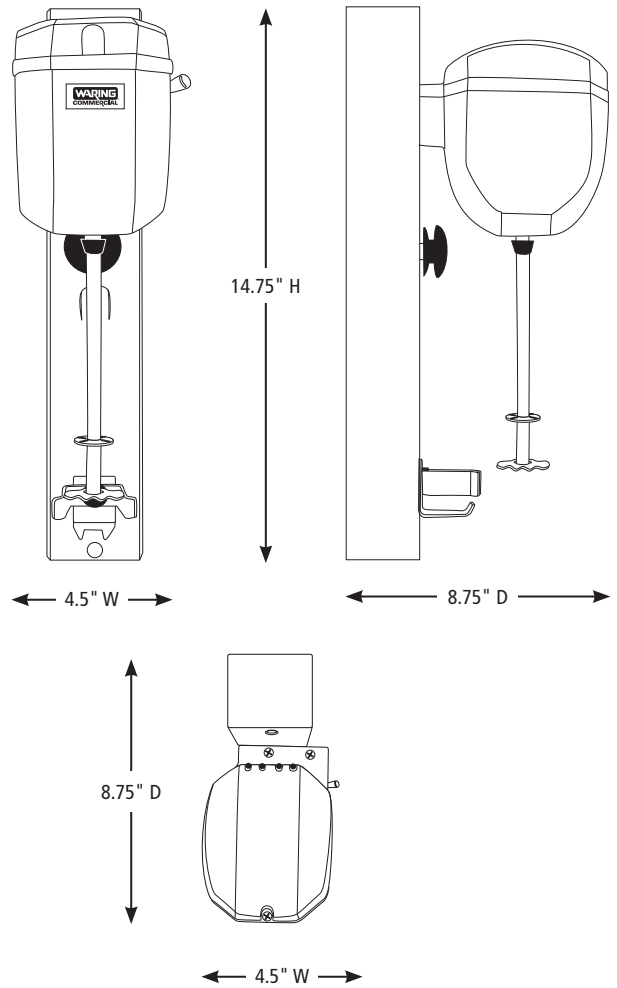

Out of Box Weight: 5 lb.

ORDERING INFORMATION	#STD. PKG.	GIFTBOX WEIGHT	CUBIC FEET	BOX DIMENSIONS D X W X H	UPC	CASE PKG.	MC WEIGHT	MC DIMENSIONS D X W X H	MBC
DMC180CA – Wall-Mount Drink Mixer	2	5.35	.304	14.7" x 4.75" x 7.5"	040072010453	4	21.4	15.5" x 10.7" x 16.1"	10040072010450



@waringcommercial

©2020 Waring Commercial
314 Ella T. Grasso Avenue, Torrington, CT 06790
Tel. 800-492-7464 • Fax 860-496-9008

waringcommercialproducts.com

20WC072942 / REV 03/20