

# WARING COMMERCIAL®

Wall Mount Drink Mixers  
with Chrome Head

**DMC180DCA**  
**DMC180DCAGR**  
Grainger

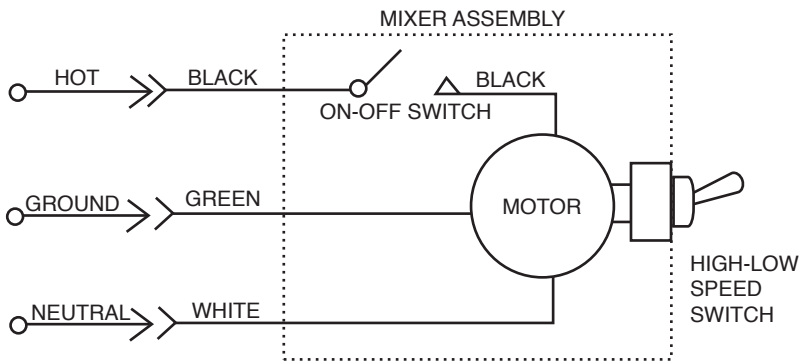

## Unit Information

1 HP peak – 1.0 Amps  
Designed to Operate with  
Rolled-top Milk Shake Containers.  
High-Low Speed Toggle Switch  
on Motor Housing.  
On-Off Actuator Knob Switch  
on Unit Body.

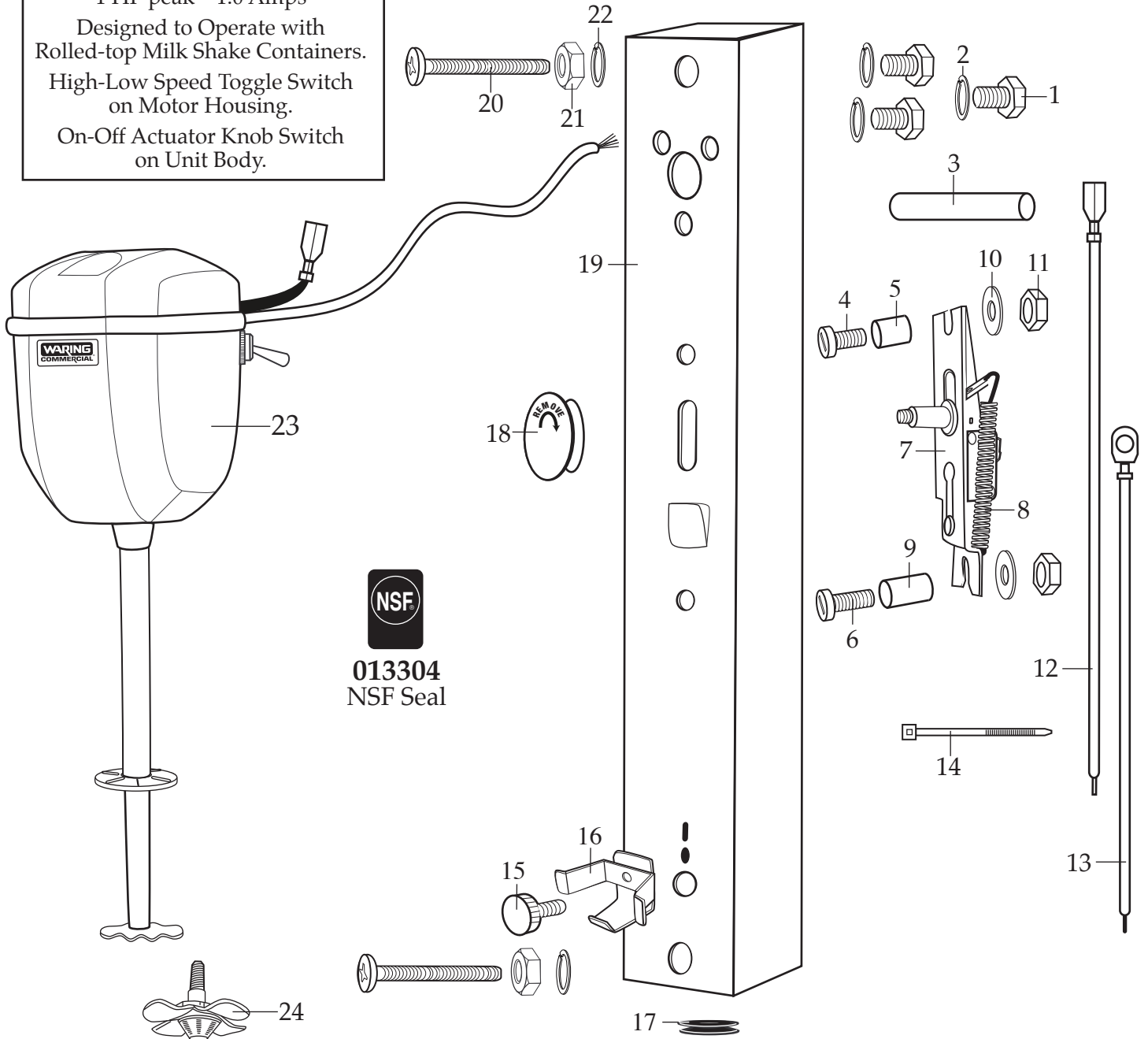

## Catalog/Model

DMC180DCA

DMC180DCAGR

# WARING COMMERCIAL

314 Ella T. Grasso Ave.

Torrington, CT 06790

Tele. 1-800-269-6640

Fax 860-496-9017

[www.waringcommercialproducts.com](http://www.waringcommercialproducts.com)

Illustration#	Part#	Description
1	032418	Bolt (3 required)
2	029273	Washer (3 required)
3	032419	Sleeve
4	032420	Screw
5	016182	Short Spacer
6	016179	Screw
7	030318	Switch
8	029275	Return Switch Spring
9	016181	Long Spacer
10	032421	Washer (2 required)
11	032422	Hex Nut (2 required)
12	032423	Black Lead
13	032424	Green Lead
14	013731	Wire Tie (2 required)
15	013918	Container Support Screw
16	015551	Container Support
17	032425	Lead Protector (hardware)
18	030319	Knob (screw on)
19	501496	Body
20	016183 027399	DMC180DCA Mounting Hardware Screw (2 required) DMC180DCAGR Mounting Hardware Screw (2 required)
21	016189	Mounting Hardware Hex Nut (2 required)
22	029273	Mounting Hardware Washer (2 required)
23	029289	Chrome Motor Head (comes with 029290 disk agitator & 029291 screw)
24	029292	Butterfly Agitator