

WARING COMMERCIAL

Xtreme Blender with Paddle Switches
and 64 oz. Stainless Steel Container

MX1000XTS

Unit Information

Limited 3 Year Motor Warranty
Two Year Parts & Labor

60Hz - 13 Amps

Height 19" - Weight 15 lbs.

3 HP Motor

30,000+ RPM's

One Piece Dishwasher Safe
Removable Jar Pad

503351
MX Coupling Wrench
(optional)

032483
Blending Assembly Kit

013304
NSF Seal

032761 (CAC119)
MX Jar Wrench
(optional)

NEMA 5-15

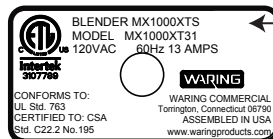

Date Code Location
YY MM|DD
year year | month month | day day

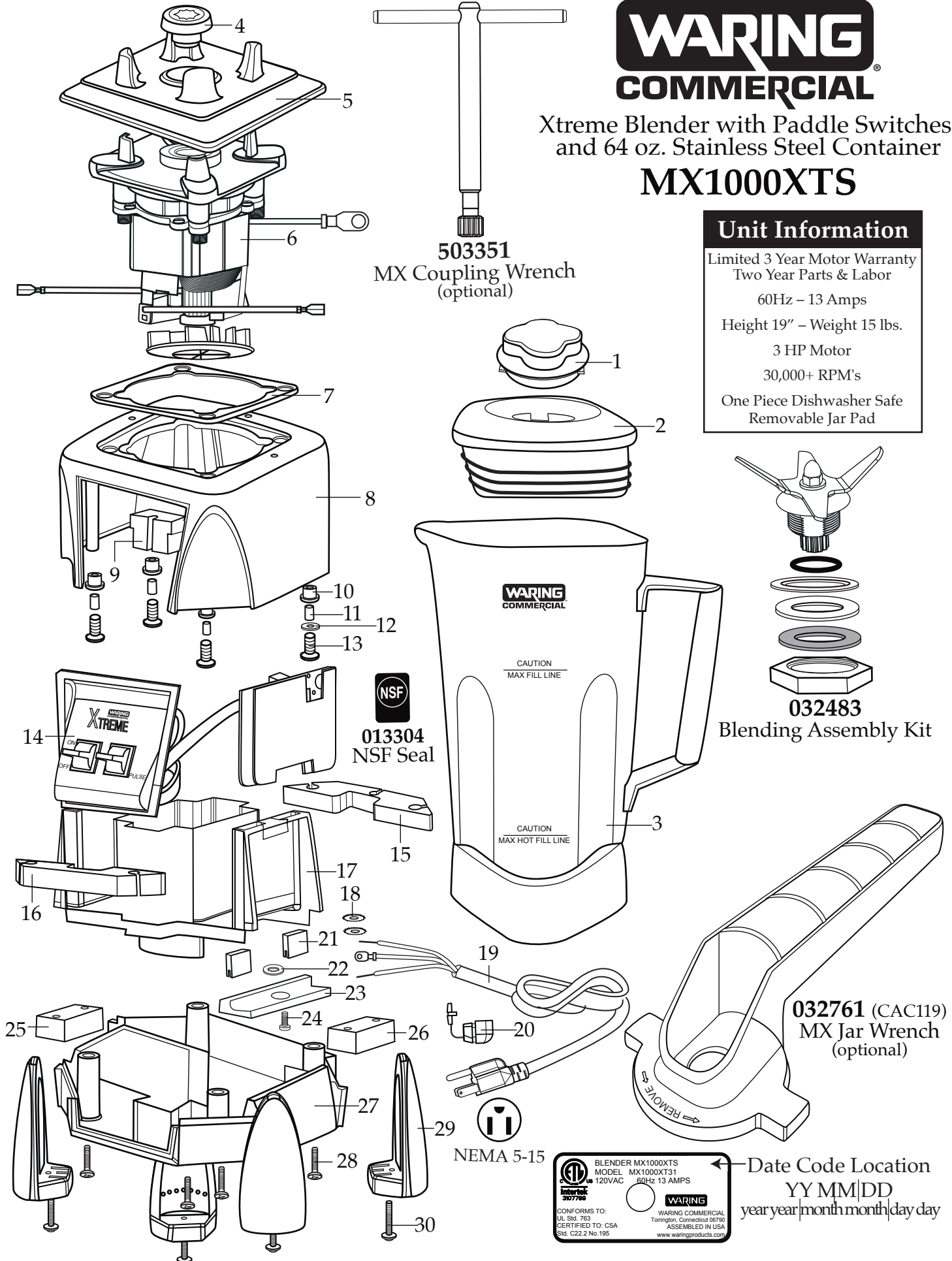

Illustration#	Part#	Description
1	026425-E	Eastman Jar Lid Cover <i>(changed after 5/26/2010)</i>
2	026424-V	Jar Lid <i>(changed after 11/20/2012)</i>
3	503346	64 oz. Stainless Steel Container Complete <i>(changed after 4/5/2010)</i>
4	503601	Sq. Drive Coupling with Adapter <i>(on units after 3/29/2022)</i>
	503604	Sq. Drive Coupling with Adapter Gen 2 <i>(on units after 5/5/2021)</i>
	028538	Drive Coupling
5	026442	Jar Pad
6	035396	Leili Motor without Sensor <i>(on units after 7/28/2017)</i>
	028100	ECM Motor without Sensor <i>(obsolete)</i>
7	038278	Dampening Plate Gasket <i>(on units after 8/25/2022)</i>
	026437	Dampening Plate Gasket
8	028032-09	Top Housing /black
9	028541	Motor Foam (2 required)
10	026439	Dampening Plate Bushing (4 required)
11	038486	Dampening Plate Sleeve (4 required <i>on units after 8/25/2022</i>)
	026453	Dampening Plate Sleeve (4 required)
12	026459	Washer
13	028929	Sems (4 required <i>on units after 8/10/2007</i>)
	026459	Washer (4 required)
	026455	Screw (4 required)
14	036394	Control Panel with Interlock <i>(on units after 2/7/2019)</i> comes with key board-main board
	033465	Soft Start Sealed Switch Control Panel <i>(changed after 6/5/2013 use 036394)</i>
	029808	Use 033465 <i>(changed after 1/10/2011)</i>
	028388	Use 029808
15	028248	Top Housing Foam Rear Baffle
16	028249	Top Housing Foam Front Baffle
17	036814	Motor Housing 2.78" <i>(on units after 7/17/2019)</i>
	028240-67	67 mm Motor Housing <i>(on units after 7/28/2017)</i>
	028240	Motor Housing
18	002943	Washer (2 required)
19	026925	Cord Set
20	007556	Strain Relief
21	034900	PCB Cushions (2 required <i>on units 7/18/2019</i>)
22	037232	Neoprene Washer <i>(on units after 7/18/2019)</i>
23	037007	PCB Mounting Bracket <i>(on units after 7/18/2019)</i>
24	013768	Screw <i>(on units after 7/18/2019)</i>
25	028247	Bottom Housing Foam Baffle
26	028542	Foam Baffle
27	028241-09-X	Bottom Housing /black
28	012505	Screw (4 required)
29	026430	Corner Post (4 required)

Illustration#	Part#	Description
30	028928 026459 012505	Sems (4 required <i>on units after 8/10/2007</i>) Washer (4 required) Screw (4 required)
31	503566 503345	Blade Assembly (<i>on units after 2/1/2019</i>) Blade Assembly (<i>changed after 4/5/2010</i>)
32	024271	O Ring
33	026798	Support Washer
34	026648	64 oz. Stainless Steel Container ONLY
35	026649	Container Support
36	026797	Bearing Holder Gasket
37	026796	Bearing Holder Washer
38	026795	Stainless Steel Jar Bearing Holder Nut

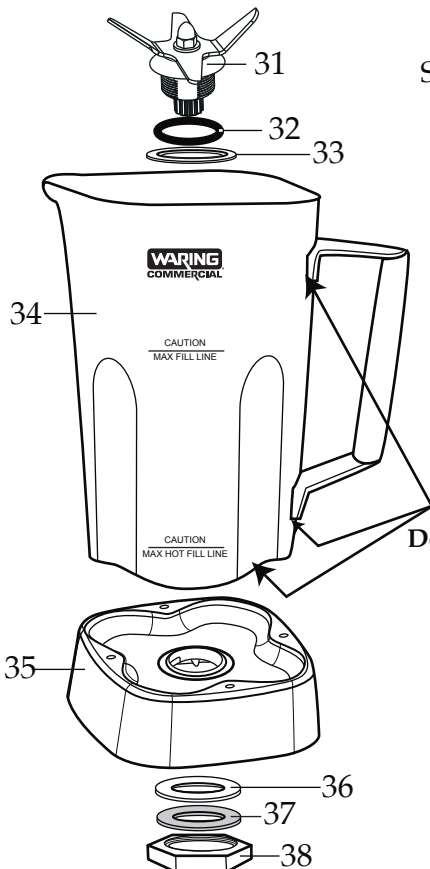

503346
 Stainless Steel Container with
 Blending Assembly
(changed after 4/5/2010)

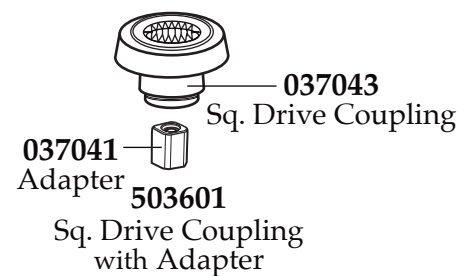
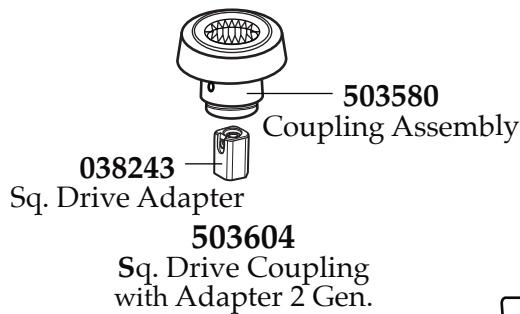

Notes for 503346 :
 Sealant applied all round
 these indicated areas.
Dow Corning Sealant RTV 733
 Torque 100-125 in / lbs.
 Lubricant applied to O Ring
Dow Corning 200 (R) Fluid

Wiring Diagram
(on units after 6/5/2013)

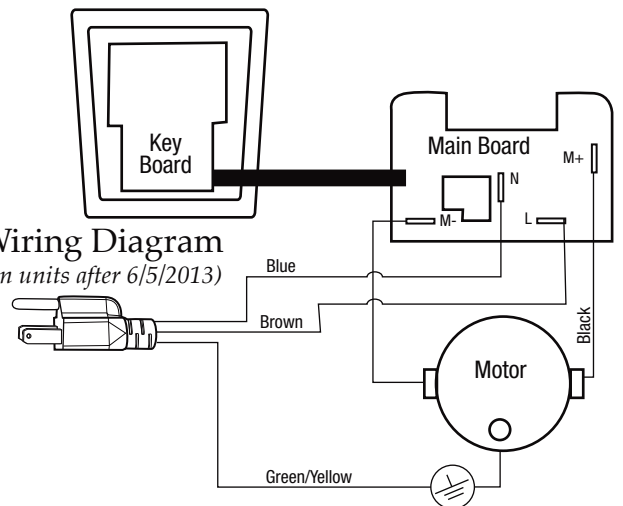

Wiring Diagram

