

# WARING COMMERCIAL

X Prep Blender with Variable Speed  
and a 64 oz. Stainless Steel Container

## MX1200XTS

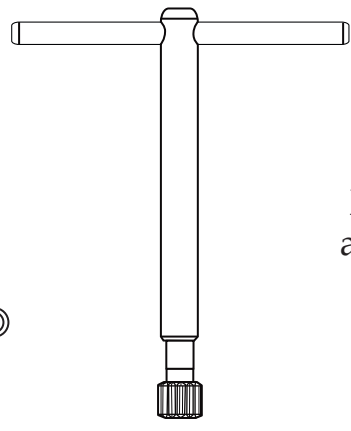
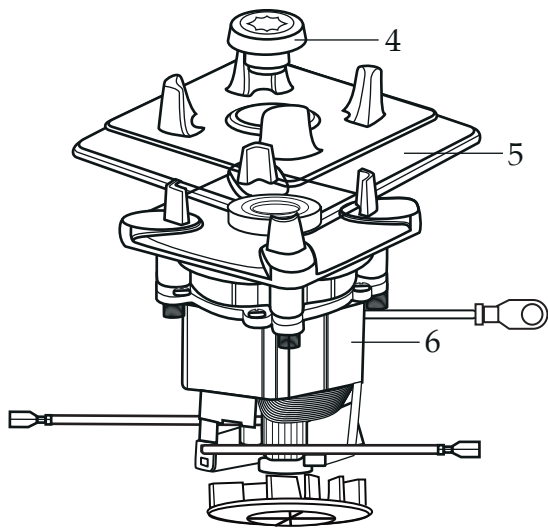

**503351**  
MX Coupling Wrench  
(optional)

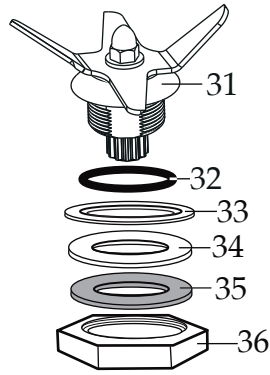
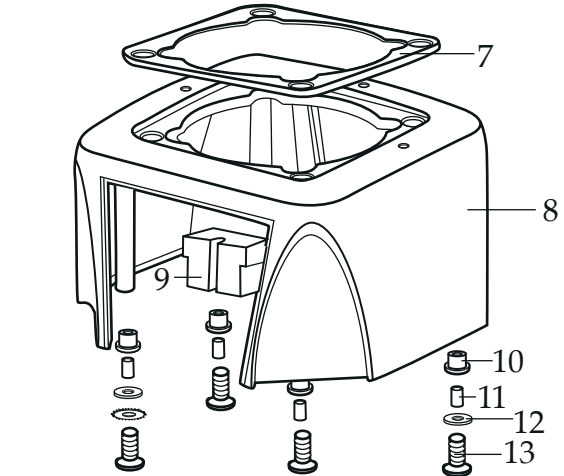

**032483**  
Blending Assembly Kit

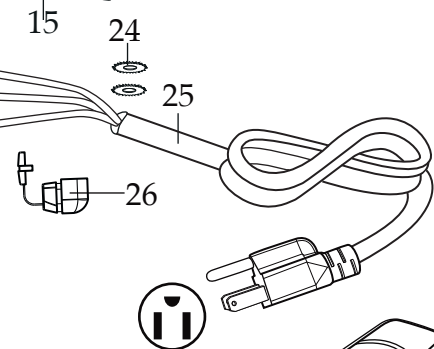
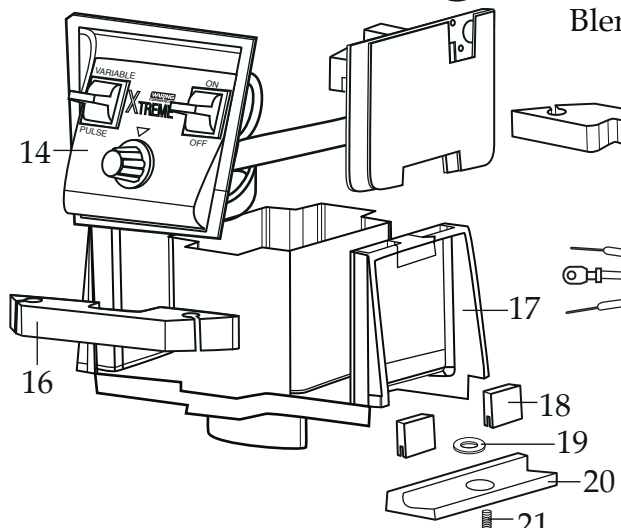

NEMA 5-15

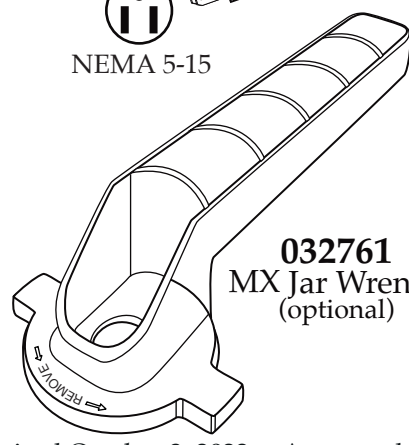
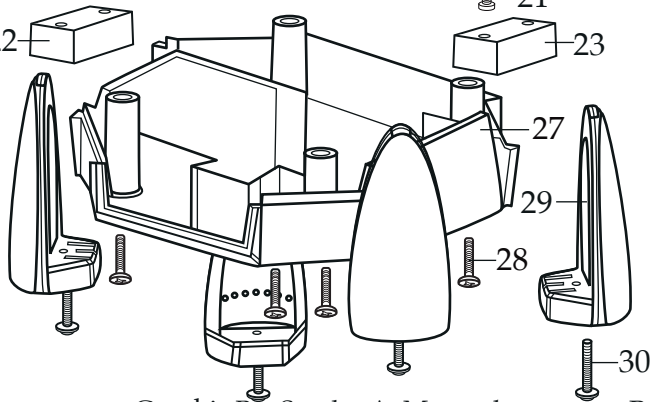

**032761**  
MX Jar Wrench  
(optional)



**013304**  
NSF Seal

### Unit Information

Limited 3 Year Motor Warranty  
Two Year Parts & Labor  
60Hz - 13 Amps  
Height 19" - Weight 15 lbs.  
3 HP Motor  
RPM's Variable 1,500-20,000  
Pulse 30,000  
One Piece Dishwasher Safe  
Removable Jar Pad

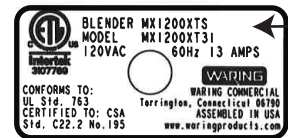

Date Code | Location  
YY MM DD  
year year | month month | day day

Illustration#	Part#	Description
1	026425-E	Eastman Jar Lid Cover <i>(changed after 2/6/2009)</i>
2	026424-V	Vinyl Jar Lid <i>(changed after 12/7/2012)</i>
3	503346	64 oz. Stainless Steel Container with Blending Assembly <i>(on units after 2/21/2011)</i>
	503372	64 oz. Stainless Steel Container with Blending Assembly
4	501601	Sq. Drive Coupling with Adapter <i>(on units after 3/29/2022)</i>
	501604	Sq. Drive Coupling with Adapter 2 Gen <i>(changed after 5/7/2021)</i>
	028538	Drive Coupling
5	026442	Jar Pad
6	035397	Leili Motor with Sensor <i>(on units after 7/28/2017)</i>
	028101	ECM Motor with Sensor
7	038278	Dampening Plate Gasket <i>(on units after 8/25/2022)</i>
	026437	Dampening Plate Gasket
8	028032-09	Top Housing black
9	028541	Motor Foam (2 required)
10	026439	Dampening Plate Bushing (4 required)
11	038486	Dampening Plate Sleeve (4 required <i>on units after 8/25/2022</i> )
	026453	Dampening Plate Sleeve (4 required)
12	026459	Washer (2 required)
13	028929	Sems (4 required <i>on units after 3/28/2007</i> )
	026459	Washer (4 required)
	026455	Screw (4 required)
14	036400	Control Panel with Interlock <i>(on units after 9/7/2018)</i> comes with switches-key board-main board
	035013	XPrep Microprocessor Control Panel <i>(changed after 4/17/2015 use 036400)</i>
	034122	XPrep Control Panel <i>(use 035013 on units after 1/10/2014)</i>
	033467	XTreme Control Panel <i>(use 034122 on units after 6/20/2013)</i>
	029811	XTreme Control Panel <i>(use 033467 on units after 10/29/2011)</i>
	028268	XTreme Control Panel <i>(use 033467)</i>
15	028248	Top Housing Foam Rear Baffle
16	028249	Top Housing Foam Front Baffle
17	036814	Motor Housing 2.78" <i>(on units after 4/10/2019)</i>
	028240-67	67 mm Motor Housing <i>(on units after 7/28/2017)</i>
	028240	Motor Housing
18	034900	PCB Cushions (2 required <i>on units after 4/10/19</i> )
19	037232	Neoprene Washer <i>(on units after 4/10/2019)</i>
20	037007	PCB Mounting Bracket <i>(on units after 4/10/2019)</i>
21	013768	Screw <i>(on units after 4/10/2019)</i>
22	002943	Washer (3 required)
23	028247	Bottom Housing Foam Baffle
24	028542	Foam Baffle
25	026925	Cord Set
26	007556	Strain Relief
27	028241-09-X	Bottom Housing /black

Illustration#	Part#	Description
29	026430	Corner Post (4 required)
30	028928	Sems (4 required <i>on units after 3/28/2007</i> )
	026459	Washer (4 required)
	012505	Screw (4 required)
31	503566	Blade Assembly ( <i>on units after 2/1/2019</i> )
	503345	Blade Assembly ( <i>changed after 2/21/2011</i> )
32	024271	O Ring
33	026798	Support Washer
34	026797	Bearing Holder Gasket
35	026796	Bearing Holder Washer
36	026795	Stainless Steel Jar Bearing Holder Nut
37	026648	64 oz. Stainless Steel Container ONLY
38	026649	Container Support

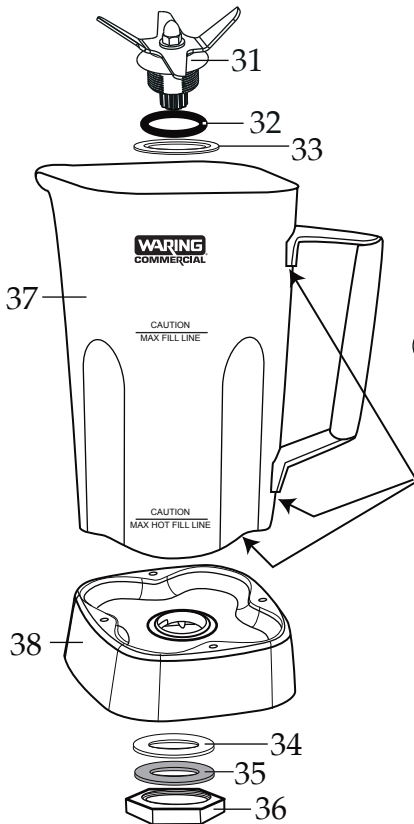

**503346**  
 64 oz. Stainless Steel Container  
 with Blending Assembly  
*(on units after 2/21/2011)*

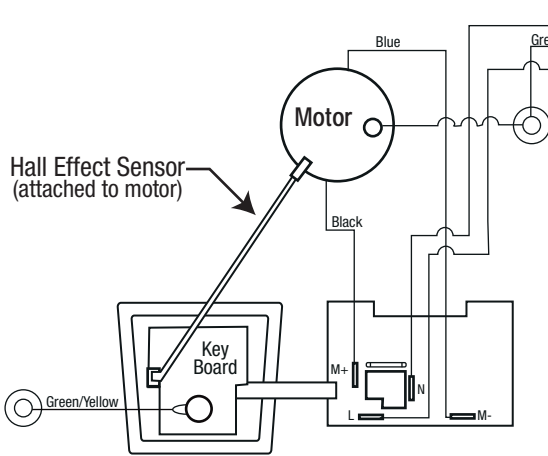

**Wiring Diagram**  
*(on units after 10/9/2012)*

**Notes for 503346 & 503372:**  
 Sealant applied all round these  
 indicated areas.  
**Dow Corning Sealant RTV 733**  
 Torque 100-125 in/lbs  
 Lubricant applied to O Ring  
**Dow Corning 200 (R) Fluid**

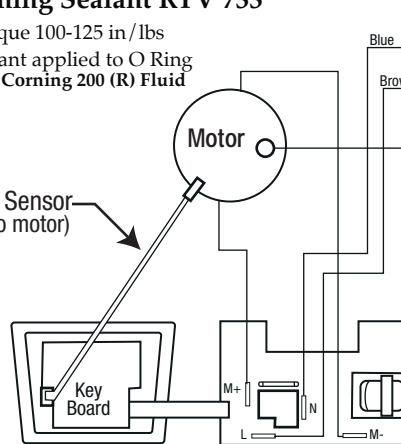

**Wiring Diagram**

