



# MX1300XTS

## Reprogrammable Hi-Power Blender with 64 oz. Stainless Steel Container



\*Made in USA with US and foreign parts.

### ELECTRICAL

Voltage: 120V

Frequency: 60Hz

Watts: 1560W

Amps: 12.5A

Plug Type: NEMA 5-15P

Cord Length: 6 feet



### MAIN FEATURES

- Heavy-duty, high-performance 3½ peak HP motor with adjustable speed controls is the strongest in its class. It powers through the toughest ice and frozen fruit mixtures in seconds.
- Super-high 30,000 RPM motor speed for the smoothest consistencies.
- 4 reprogrammable beverage stations for perfect results every time.
  - Factory-set programs for the most popular beverage types
  - Easy to create your own customized programs – fully reprogrammable directly on the keyboard with no need for a USB or computer for programming
- Daily and total drink counter display.
- Variable speed and time selections for maximum control over consistencies.
- Dual PULSE feature with reprogrammable speed control.
- Easy-to-clean electronic-membrane keypad.
  - Premium, stainless steel container with 64 oz. capacity and cloverleaf jar design creates high-power vortex, funneling food directly into the blade. Unbreakable and dishwasher safe.
- Optional sound enclosure easily retrofits to base for noise reduction.
- High-performance, high-impact stainless steel blade is user replaceable for easy servicing.
- User-replaceable, metal-on-metal stainless steel coupling system for durability and reliability.
- Easily removable container cover with removable clear cap lets you add ingredients and reduce pressure during hot food blending.
- One-piece, dishwasher-safe, removable jar pad.
- Recommended for 75+ cycles per day.
- Limited Three-Year Motor and Two-Year Parts and Labor Warranty.

### SALES FEATURES

Get smooth, consistent results every time with the Waring® MX1300XTS. This heavy-duty 3½ peak HP blender teams up with our stainless steel jar/ blade assembly for maximum power and efficiency. It's ferocious enough for everything from smoothies and frozen drinks to thick spreads, desserts, dressings, and all types of food preparation. The sturdy base features an easy-to-clean electronic-membrane keypad with blue backlit LCD screen and four reprogrammable beverage stations. Blend 75+ cycles per day.

Reprogrammable Hi-Power Blender with 64 oz. Stainless Steel Container

MX1300XTS



@waringcommercial

©2022 Waring Commercial  
314 Ella T. Grasso Avenue, Torrington, CT 06790  
Tel. 800-492-7464 • Fax 860-496-9008

waringcommercialproducts.com



# Reprogrammable Hi-Power Blender with 64 oz. Stainless Steel Container MX1300XTS

## PARTS & ACCESSORIES

- |   |  |   |  |
|---|--|---|--|
|    | <b>CAC90</b><br>64 oz. Stainless Steel Container   |    | <b>CAC95-12</b><br>64 oz. Green Copolyester Container                      |
|    | <b>CAC93X</b><br>48 oz. Copolyester Container  |    | <b>CAC95-28</b><br>64 oz. Orange Copolyester Container                     |
|    | <b>CAC93X-03</b><br>48 oz. Yellow Copolyester Container  |    | <b>CAC116</b><br>Blending Assembly Kit and Retainer Ring Kit               |
|    | <b>CAC93X-06</b><br>48 oz. Blue Copolyester Container  |    | <b>CAC119</b><br>Retainer Ring Wrench                                      |
|    | <b>CAC93X-10</b><br>48 oz. Purple Copolyester Container  |    | <b>CAC158</b><br>Blending Assembly Kit                                     |
|    | <b>CAC93X-12</b><br>48 oz. Green Copolyester Container   |    | <b>CAC159</b><br>Retainer Ring Kit   |
|   | <b>CAC93X-28</b><br>48 oz. Orange Copolyester Container  |    | <b>CAC160</b><br>Drive Coupling  |
|  | <b>CAC95</b><br>The Raptor® – Aggressive, All-Purpose, Stackable, 64 oz., BPA-Free Copolyester Container |  | <b>CAC161</b><br>Drive Coupling Removal Tool                               |
|  | <b>CAC95-03</b><br>64 oz. Yellow Copolyester Container   |  | <b>CAC169</b><br>Spatula – Custom designed for use with MX Series Blenders |
|  | <b>CAC95-06</b><br>64 oz. Blue Copolyester Container   |  | <b>SE1000</b><br>Large Sound Enclosure                                     |
|  | <b>CAC95-10</b><br>64 oz. Purple Copolyester Container   |  | <b>SE500</b><br>Small Sound Enclosure                                      |

## DIMENSIONS

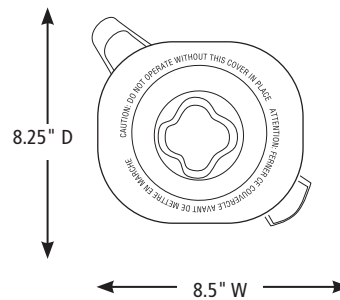
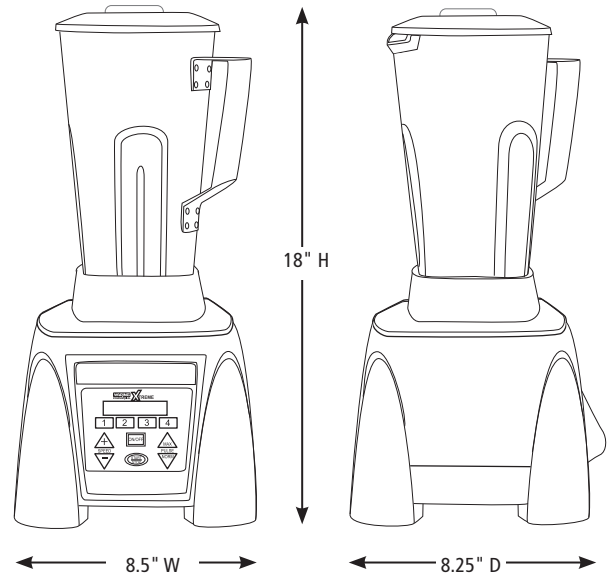

Out-of-Box Weight: 17 lb.

ORDERING INFORMATION	#STD. PKG.	GIFTBOX WEIGHT	CUBIC FEET	BOX DIMENSIONS D X W X H	UPC	CASE PKG.	MC WEIGHT	MC DIMENSIONS D X W X H	MBC
MX1300XTS– Reprogrammable Hi-Power Blender with 64 oz. Stainless Steel Container	1	18.15 lb.	1.037	11.375" x 10.250" x 15.375"	040072006852	1	19.1 lb.	11.875" x 10.875" x 16.375"	10040072006859



@waringcommercial

©2022 Waring Commercial  
314 Ella T. Grasso Avenue, Torrington, CT 06790  
Tel. 800-492-7464 • Fax 860-496-9008

waringcommercialproducts.com

22WC084409 / REV 07/22