

WARING
COMMERCIAL



JE2000
JUICE EXTRACTOR
WITH PULP EJECTOR

IMPORTANT SAFEGUARDS

When using electrical appliances, basic safety precautions should always be followed, including the following:

1. **READ ALL INSTRUCTIONS.**
2. To protect against risk of electrical shock do not put motor base housing, shown in Figure A of your manual, in water or other liquid.
3. Close supervision is necessary when any appliance is used by or near children.
4. Always unplug from outlet when not in use, before putting on or taking off parts, and before cleaning.
5. Avoid contacting moving parts.
6. Do not operate any appliance with a damaged cord or plug or after the appliance malfunctions or has been dropped or damaged in any manner. Return appliance to the nearest authorized service facility for examination, repair, or electrical or mechanical adjustment.
7. The use of any attachments not recommended or sold by the manufacturer may cause fire, electric shock or injury.
8. Do not use outdoors.
9. Do not let cord hang over edge of table or counter, or touch hot surfaces.
10. Always make sure juicer lid is secure beneath latching bar before motor is turned on. Do not loosen lid while Juice Extractor is in operation.
11. Be sure to turn switch to “off” position after each use of your Juice Extractor. Make sure the motor stops completely and is unplugged before disassembling.
12. Do not put your fingers or other foreign objects into the Juice Extractor opening while it is in operation. If food becomes lodged in opening, use food plunger or another piece of fruit or vegetable to push it down. Do not push with fingers. When this method is not possible, turn the motor off and disassemble juicer to remove the remaining food.

SAVE THESE INSTRUCTIONS

For your record,
please fill in this
information for
future use.

Product _____
Serial No. _____
Date of Purchase _____
Purchased from _____
Catalog No. _____

CONTENTS

	Page
Wonderful New Nutritional Experience	3
Operating Instructions	4
Cleaning & Disassembly	5
Figure A.	6
Tips for Juicing Properly	7-8
Suggestions for Juice Combinations	9
Uses of Pulp	9
Parts List	9
Exploded Diagram of JE2000	10
Parts & Service List	11-12

A WONDERFUL NEW NUTRITIONAL EXPERIENCE

Raw juices derived from fresh fruits and vegetables are invaluable in helping maintain a balanced diet. Raw juice is highly assimilable and contains, in its most natural and complete form, precious vitamins and minerals, bioflavonoids and enzymes. In addition, nutritional authorities state that raw juice is food in easily digested form.

For best results, use your Waring® Commercial Juice Extractor in the manner recommended in this instruction manual.

For new consumers, because of the cleansing and rebuilding properties contained in juices, it is recommended that you initially consume juices in small amounts the first week, and then gradually increase amounts as you can comfortably enjoy them in accordance with juice book recommendations.

Vegetable juices can be mixed, but if fruit juices are added, do not use more than one kind. It is recommended that fruit juices be taken alone, between meals, and at room temperature.

For further information on the consumption of juices, we recommend that you visit your health food store and pick up one of the many juice books available on this subject.

The Waring® Commercial Juice Extractor is the result of years of intensive research and scientific developments, and we feel sure you will be delighted with its precise performance.

OPERATING INSTRUCTIONS

GENERAL INFORMATION

The fruits or vegetables should be introduced into the machine after the machine is running. When the machine is connected, use only the plunger (017974) to process fruits and vegetables, do not use hands. The juices are kept pure by insuring that all parts in direct contact with food are manufactured from the highest quality stainless steel.

At the end of each juicing process we suggest that you add a wedge of lemon to the juices because it helps to keep them from discoloring.

Care should be exercised when handling the strainer (017963), as dropping or rough treatment in the sink can damage its balance or precision screen material.

VERY IMPORTANT

Before using the machine, check that it is plugged into a 120V AC electrical supply with grounded outlet.

Before using the machine, we also suggest that you wash the following parts with hot water and mild detergent:

- a. Plunger (017974)
- b. Cover with Pulp Deflector (017972)
- c. Filter Strainer (017963), Shredder (017971), Shredder Hub Screw (017977)
removable with the Tool (017978)
- d. Bowl with Spout (017964)
- e. Pulp Container (017973)

ATTENTION: The Top Housing unit should be cleaned only with a wet sponge.

ASSEMBLY

Ensure that the cover with pulp deflector (017972), the shredder (017971), the shredder hub screw (017977) and the bowl with spout (017964) are securely assembled with the bar clamp (017966).

CLEANING & DISASSEMBLY

CLEANING

- a. Unplug the machine from electrical outlet.
- b. Disassemble all the washable pieces of the machine and rinse in cold water.
Note: Never immerse or pour water on the lower part of machine containing motor – clean motor housing using only a wet sponge.
- c. It is sufficient to put each piece under cold water. Should the machine remain unused for a long time without being washed, use warm water, mild detergent and scrub strainer with cleaning brush provided.
- d. Important: When using some types of fruits or vegetables, especially carrots, a layer may form which can gradually close the filter. It is necessary to soak the Filter Strainer (017963) at least once a week overnight in water with dishwasher detergent (e.g. 8 tablespoons of “Cascade” or equivalent per gallon).

DISASSEMBLY (See Fig. A)

1. Remove plunger.
2. Unlock lock toggle bar (Rotate Up) and remove cover with pulp deflector.
3. Remove shredder and filter strainer by removing shredder hub screw, turning it counterclockwise using tool (017978).
Note: Gently holding the top rim of the filter strainer with the opposite hand is usually sufficient for undoing shredder hub screw, but if screw has become stuck, we have provided a locking button.

The locking button must be firmly pressed and filter strainer rotated until button engages. This will lock rotary shaft while required torque is applied with Shredder Hub tool to break shredder hub screw loose.
4. Once the screw is removed, shredder, filter strainer and bowl with spout are easily removed simultaneously by lifting vertically off the bowl.

FIGURE A

Note:

1. To loosen shredder hub screw, gently hold top rim of the filter and turn shredder hub screw counterclockwise, using tool. However, if this becomes difficult, push and hold locking button.
2. To disassemble unit, place bar over top cover and hold lock toggle bar in upward position to unlock or in downward position to lock.
3. This machine has a safety interlock and will not run unless locking toggle bar is in a downward position.

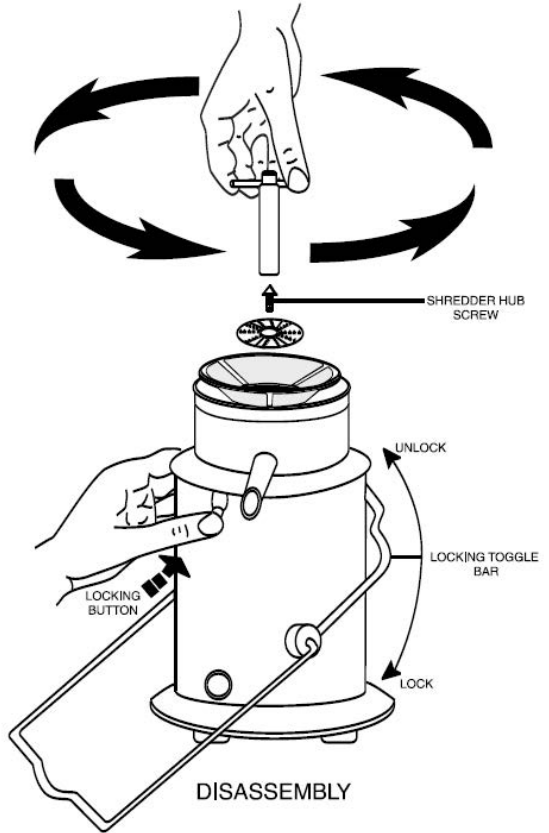

TIPS FOR JUICING PROPERLY

The Waring® Commercial Juice Extractor is a precision machine and the following hints will help you obtain optimum performance. Vegetables should always be fresh and crisp. All fruits and vegetables should be fed through the feeder chute. Cut all vegetables in the largest pieces possible for feeding. With hard fruits and vegetables (carrots, beets, celery, etc.) we recommend a steady, light push. With softer fruits and vegetables (apples, cucumbers), we recommend a slow, even feeding motion to allow the skins to be torn apart completely. The Waring® Juice Extractor is a centrifugal pulp-ejecting type juicer; by following the instructions above, you can avoid juicer vibration.

PREPARATION OF FRUITS AND VEGETABLES

Fruit or vegetable should be washed before being used. (It is necessary to wash the vegetable or fruit in order to remove foreign matter and pesticides).

The fruit or vegetable should be cut before being introduced into the machine, in order to simplify the work (for instance the apple in four pieces). It is necessary to remove the pits from the fruit (for instance, peaches, cherries, etc.). For citrus fruit, we recommend removing skins. Otherwise, juice will have a bitter taste.

THE VITAMIN & MINERAL CONTENT OF MOST POPULAR JUICES AND “HOW TO JUICE”

We have listed some of the most popular fruits and vegetables used for juicing. Of course, there may be fruits or vegetables we have not listed, so please apply the following instructions to any similar fruit or vegetable.

CARROT JUICE

A, B, C and G

Potassium, Iron, Magnesium, Calcium, Manganese,
Sodium, Silicon and Iodine

Carrot juice, the favorite of many people, can be mixed with most any other juice to make a tasty blend.

Carrots should be scrubbed with a vegetable brush.

Do not peel or cut into small pieces. Leave carrots whole, and cut them only if they are too large to fit into the feeder chute. For best juice extraction, carrots should be juiced at room temperature rather than cold. Carrot juice should be consumed as soon as it is made, or can be stored in the refrigerator for use the same day. Add a few drops of orange or lemon juice, to keep its color much longer.

CABBAGE JUICE

A, B, C, G and U

Chlorine, Calcium, Sodium and Iron

After washing, cut into wedges that can be fed into the juicer.

CELERY JUICE

A, B, C and E

Potassium, Calcium and Sulphur

Separate stalks and push into juicer with leaf end first.

BEET JUICE

A, B, C and G

Sodium, Iron, Calcium, Potassium and Chlorine

Wash thoroughly; cut into sections to fit entry tube.

Beet tops may also be juiced. See instruction for leafy vegetable juices.

CUCUMBER JUICE

B, B2, C

Potassium, Calcium, Sodium, Sulphur and Chlorine

Wash thoroughly, quarter the cucumber lengthwise and use a slow, even motion to feed. Peel if desired.

LEAFY VEGETABLE JUICE

Parsley, Lettuce, Spinach, Turnip Greens, Dandelion, Watercress, etc.

Wash thoroughly, then wrap in a dry towel and refrigerate until greens become crisp. When ready for juicing, twist and roll into a small ball and use plunger to feed. These should be juiced first when making a combination with other vegetables.

APPLE JUICE

A, B1, B2 and C

Magnesium, Iron, Silicon, Potassium, Phosphorus, Sodium, Calcium, Sulphur and Chlorine

Wash thoroughly. It is not necessary to peel or core apples, but we recommend removing the stem. Cut into sections to fit entry tube. Hard, firm apples produce the best juice.

CITRUS JUICES

Orange, Grapefruit, Lemons, etc.

Large source of Vitamin C, Pectin and Bioflavonoids, especially in white portion under peel.

Note: Very soft fruits and vegetables such as tomatoes, peaches, and grapes can be juiced; however, they should be alternately juiced with firmer fruits and vegetables.

SUGGESTIONS FOR JUICE COMBINATIONS

Many of our customers frequently request recipes and suggestions for tasty combinations of juices. This is very much a matter of individual taste, since ideas of taste-tempting juice combinations vary considerably.

Most everyone enjoys juices in their fresh form just as they come from the Juice Extractor. If this is not the case with you, you can combine different juices in proportions to suit your taste. After experimenting with different juices, everyone will find the combinations that are right for them.

Vegetables and fruit cocktails can be consumed at any time. Nothing surpasses them for helping to quicken energy, and they are delicious, nutritious drinks.

Following are some tips on tasty combinations that are being used and recommended by many of our happy Juice Extractor users. For something new and exciting, you will want to try these recipes.

1. 2/3 Carrot Juice with 1/3 Celery Juice. For improved flavor, add a few drops of lemon juice
2. 1/2 Carrot Juice - 1/2 Apple Juice
3. 3/4 Carrot Juice - 1/4 Cabbage Juice
4. 2/3 Celery Juice - 1/3 Apple Juice
5. 5 oz. Carrot Juice - 2 oz. Cucumber - 1 oz. Beet Juice
6. 4 oz. Carrot Juice - 3 oz. Celery Juice - 1 oz. Parsley (or any leafy green)
7. 4 oz. Orange Juice - 4 oz. Grapefruit Juice - 1 oz. Lemon Juice
8. 6 oz. Apple Juice - 8 oz. Carrot Juice - 2 oz. Spinach Juice
9. 2 oz. Carrot Juice - 4 oz. Apple Juice - 2 oz. Cabbage Juice
10. 7 oz. Celery Juice - 1 oz. Lemon Juice
11. 4 oz. Apple Juice - 4 oz. Orange Juice

As you use your Waring® Commercial Juice Extractor, you may come up with new combinations that you want to share. We would love to hear from you concerning any delightful new discoveries you make. You may contact us at service@waringproducts.com.

USES OF PULP

With the Waring® Commercial Juice Extractor, nothing is wasted.

Pulp may be used for flavoring in soups, casseroles, breads, cakes, cookies, sauces, salads, and JELL-O® brand gelatin molds. Many people also use the pulp as compost for gardens, shrubbery, flowers and plants.

WARING
COMMERCIAL®

JE2000

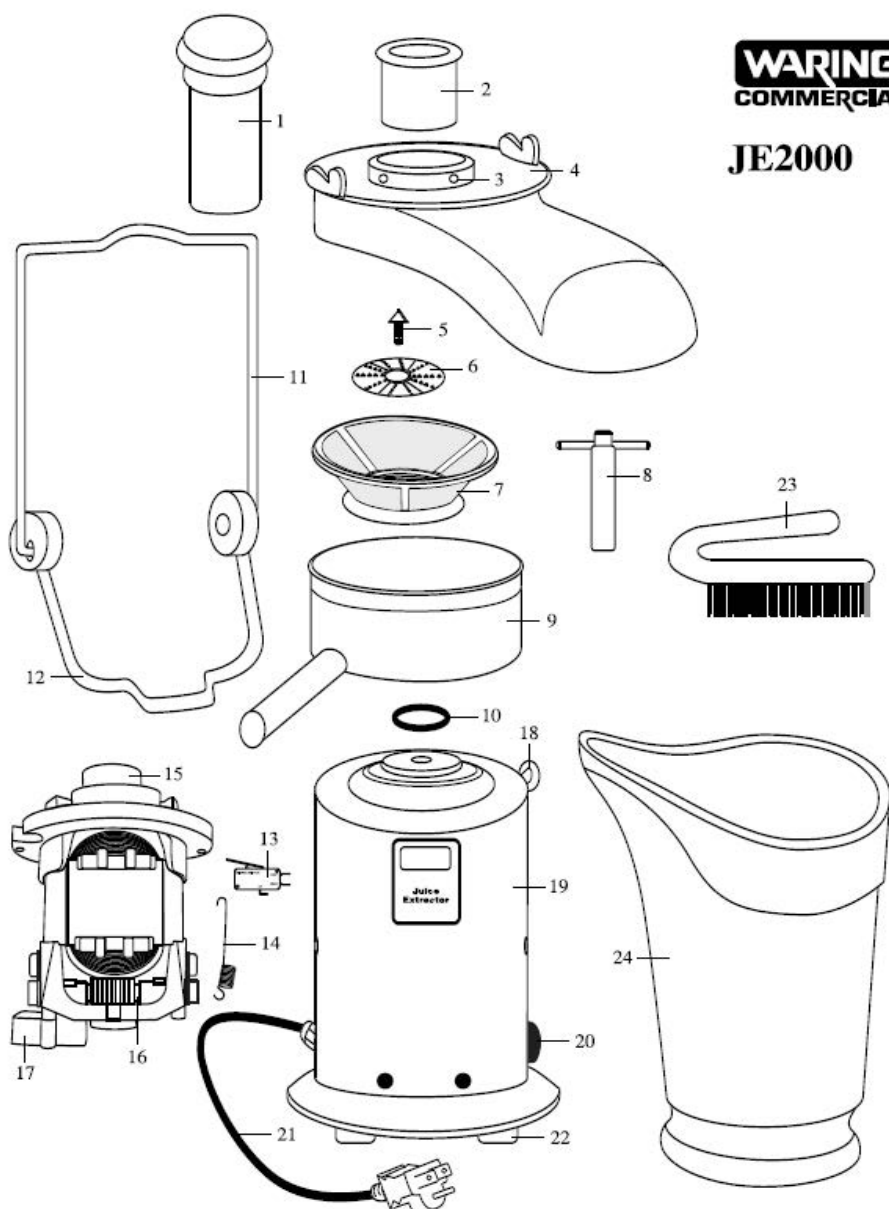

PARTS LIST

If for any reason parts are to be ordered, please do so by name and part number as listed. Parts may be ordered from any Authorized Service Center. Be sure to give Model and Serial number from bottom of machine when ordering.

CATALOG
JE2000

MODEL
31JE54

P.O. BOX 3201
314 ELLA T. GRASSO AVENUE
TORRINGTON, CT 06790
TEL # 1-800-492-7464
FAX # 1-860-796-9017
EMAIL: sales@waringproducts.com

Illustration#	Part#	Description
1	017974	Plunger Assy.
2	017976	Entry Tube
3	017983	Set Screw (3 Req.'d)
4	017972	Cover with Pulp Deflector
5	017977	Shredder Hub Screw
6	017971	Shredder
7	017963	Filter Strainer
8	017978	Tool shredder hub screw
9	017964	Bowl with Spout
10	017970	O Ring Seal
11	017966	Bar Clamp
12	017987	Locking Toggle
13	017982	Safety Switch
14	017988	Spring safety switch (2 Req.'d)
15	017980	Motor 1/2 hp
16	017981	Motor Brush (2 Req.'d)
17	023530	Capacitor
18	017967	Lock Stop Button
19	019624	Top Housing
20	019620	Push Button Switch
21	000150W	Cord Set
22	017984	Foot (5 Req.'d)
23	017962	Cleaning Brush
24	017973	Pulp Container one gallon

ITEMS NOT SHOWN

019619 - Strain Relief/push button switch

019179 - Upper Bearing

017986 - Screw (5 Req'd)

013092 - Lower Bearing

018772 - Screen/bottom of unit

FOR SERVICE OR PARTS, SEND TO:

Waring Service Center
P.O. Box 3201
314 Ella T. Grasso Avenue
Torrington, CT 06790

Tel # 1-800-269-6640

Fax # 1-860-496-9017

Email: service@waringproducts.com

Or any Authorized Waring Service Center.



314 Ella T. Grasso Ave.
Torrington, CT 06790
www.waringproducts.com

017954
RV030011