



WDM500

The Big Freeze® Variable Speed Drink Mixer



The Big Freeze® Variable Speed Drink Mixer



MAIN FEATURES

- Heavy-duty, steel housing
- High-performance, 1.2 peak HP, variable-speed motor
- Variable speeds from 2,500 – 12,500 RPM
- START/STOP button lets you pause the motor during mixing to add mix-ins
- Ergonomic polycarbonate splash guard ensures clean and easy operation
- PULSE function gives you a short burst of power to refresh frozen drinks
- Two agitator options: solid metal agitator for use with hard ice cream, and butterfly plastic agitator for use with soft serve, frozen yogurt and gelato
- Built for large-volume locations
- Limited One Year Warranty

SALES FEATURES

When you need to produce large batches of milkshakes, malts or other frozen drinks with mix-ins, reach for the Waring® WDM500, The Big Freeze® 1.2 peak HP Variable-Speed Single-Spindle Drink Mixer. Its high-performance, 1.2 peak HP, variable-speed motor lets you efficiently process both hard and soft ice cream, frozen yogurt and gelato using two agitator options.

ELECTRICAL

Voltage: 120

Frequency: 60Hz

Amps: 3

Plug Type: NEMA 5-15P ⓘ

Cord Length: 5 feet



@waringcommercial

©2019 Waring Commercial
 314 Ella T. Grasso Avenue, Torrington, CT 06790
 Tel. 800-492-7464 • Fax 860-496-9008

waringcommercialproducts.com

WDM500



The Big Freeze® Variable Speed Drink Mixer WDM500

PARTS & ACCESSORIES



WDM500PA Butterfly Plastic Agitator



WDM500MA Solid Metal Agitator



CAC20 28 oz. Stainless Steel Malt Cup



WDM500SG Splash Guard

DIMENSIONS

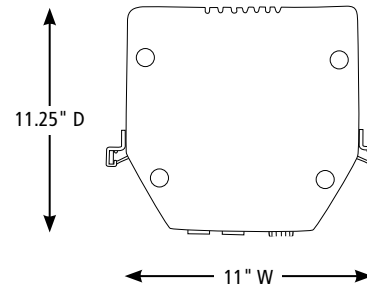
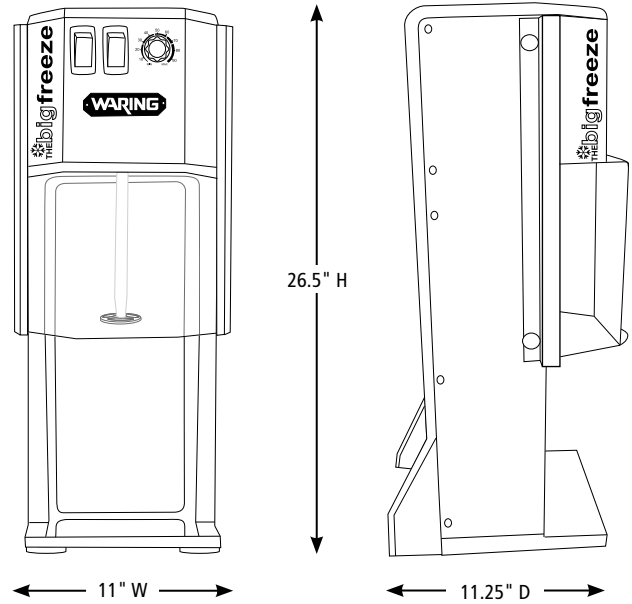

Out of Box Weight: 42 lb.

ORDERING INFORMATION	#STD. PKG.	GIFTBOX WEIGHT	CUBIC FEET	BOX DIMENSIONS D X W X H	UPC	CASE PKG.	MC WEIGHT	MC DIMENSIONS D X W X H	MBC
WDM500 – The Big Freeze® Variable Speed Drink Mixer	1	49.7	3.6	16.25" x 13.75" x 28.5"	040072022463	1	53.1	17" x 14.25" x 53.1"	10040072022460



@waringcommercial

©2019 Waring Commercial
314 Ella T. Grasso Avenue, Torrington, CT 06790
Tel. 800-492-7464 • Fax 860-496-9008

waringcommercialproducts.com

19WC059590 / REV 07/19