

WARING
COMMERCIAL

SINGLE, DOUBLE & TRIPLE SPINDLE DRINK MIXERS



Fully automatic
START/STOP operation



Increased cup clearance
– no need to tilt before
or after mixing



Butterfly and new solid
agitator for powering through
hard ice cream



- High performance 1 peak HP motor
- 3 speeds – 16,000, 22,000 and 25,000 rpm
- Momentary pulse switches pulse at selected speed
- Fully automatic START/STOP operation
- Independent airflow system for each motor
- Heavy-duty die-cast housing
- Easy user-replaceable commercial motors
- 120 VAC, 60 Hz
- Limited One-Year Warranty



WDM Series



SINGLE, DOUBLE & TRIPLE SPINDLE DRINK MIXERS

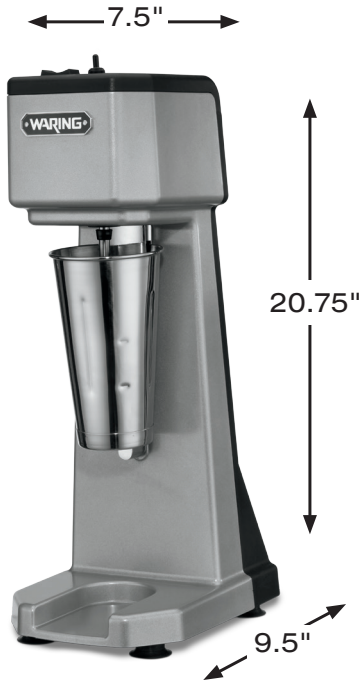

WDM120



WDM240



WDM360

ITEM	ELECTRICAL	LISTINGS	OUT OF BOX WEIGHT	OUT OF BOX DIMENSIONS (H x W x D)	CORD LENGTH	WARRANTY
WDM120	120 VAC, 60 Hz	cETLus, NSF	15.9 lb.	20.75" x 7.5" x 9.5"	2.4 Feet	Limited 1 Year
WDM240	120 VAC, 60 Hz	cETLus, NSF	26.55 lb.	20.75" x 10.75" x 13"	2.4 Feet	Limited 1 Year
WDM360	120 VAC, 60 Hz	cETLus, NSF	35.25 lb.	20.75" x 13.5" x 13.3"	2.4 Feet	Limited 1 Year

ORDERING INFORMATION	#STD. PKG.	GIFTBOX WEIGHT	CUBIC FEET	BOX DIMENSIONS (L x W x H)	UPC	MC WEIGHT	MC DIMENSIONS	MBC
WDM120	1	17.3	1.3	11.6" x 9.3" x 21.7"	040072015663	18.8	12.3" x 10.3" x 22.7"	10040072015660
WDM240	1	29.5	2.6	15" x 13.6" x 22.2"	040072022371	32.2	15.6" x 14.6" x 23"	10040072022378
WDM360	1	38.2	2.9	15.1" x 15.2" x 22.1"	040072015670	41.2	15.8" x 16.2" x 23"	10040072015677

PARTS & ACCESSORIES	UPC
CAC20 – Stainless Steel Malt Cup	040072930270
CAC123 – Butterfly Agitator	040072023538
CAC112 – Solid Agitator	040072019019



@waringcommercial

waringcommercialproducts.com

©2018 Waring Commercial
 314 Ella T. Grasso Avenue, Torrington, CT 06790
 Tel. 800-492-7464 • Fax 860-496-9008
 17WC029865