



WSM20LT

20-Quart Planetary Mixer with Integrated Digital Timer



20-Quart Planetary Mixer with Integrated Digital Timer

Luna 20

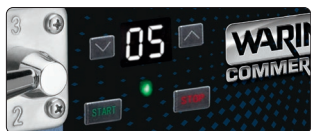

New integrated 99-minute digital timer Hub size #12

MAIN FEATURES

- Large 20-quart stainless steel bowl with stainless steel handle
- Integrated, easy-to-use 99-minute countdown timer
 - Automatically stops mixer when time reaches 0:00
 - Ensures consistent results every time
- Heavy-duty 1 HP induction motor
- Side-mounted controls
- 3 mixing speeds
- Heavy-duty bowl-lift lever
- Gear-driven, permanent lube transmission
- Thermal overload protection
- Includes stainless steel bowl, chef's whisk, dough hook, and aluminum mixing paddle
- Specifically designed for countertop use
- Nonslip rubber feet
- Limited two-year motor warranty, one-year parts & labor

ELECTRICAL

Voltage: 120

Frequency: 60Hz

Watts: 1100

Amps: 9.2

Plug Type: NEMA 5-15P ⓘ

Cord Length: 6 feet



SALES FEATURES

Equipped with a powerful 1 HP induction motor, this heavy-duty 20 qt. planetary mixer is perfect for foodservice operations in need of a dependable mixing solution. Mix ingredients for baked goods, power through batters, and more. The 3-speed variable control ensures efficiency and versatility. The new integrated countdown timer keeps the mixing process on track while providing ideal and consistent results every time. The gear-driven design with thermal overload protection makes this mixer especially reliable in any commercial kitchen.



@waringproducts

©2024 Waring
314 Ella T. Grasso Avenue, Torrington, CT 06790
Tel. 800-492-7464 • Fax 860-496-9008

waring.com

WSM20LT



20-Quart Planetary Mixer with Integrated Digital Timer WSM20LT

PARTS & ACCESSORIES



WSM20LMP Aluminum Mixing Paddle



WSM20LW Stainless Steel Chef's Whisk



WSM20LDH Stainless Steel Dough Hook



WSM20LBL 20-Quart Stainless Steel Bowl

Special shipping requirements needed. Machines ship in large wood crates via courier service.

DIMENSIONS

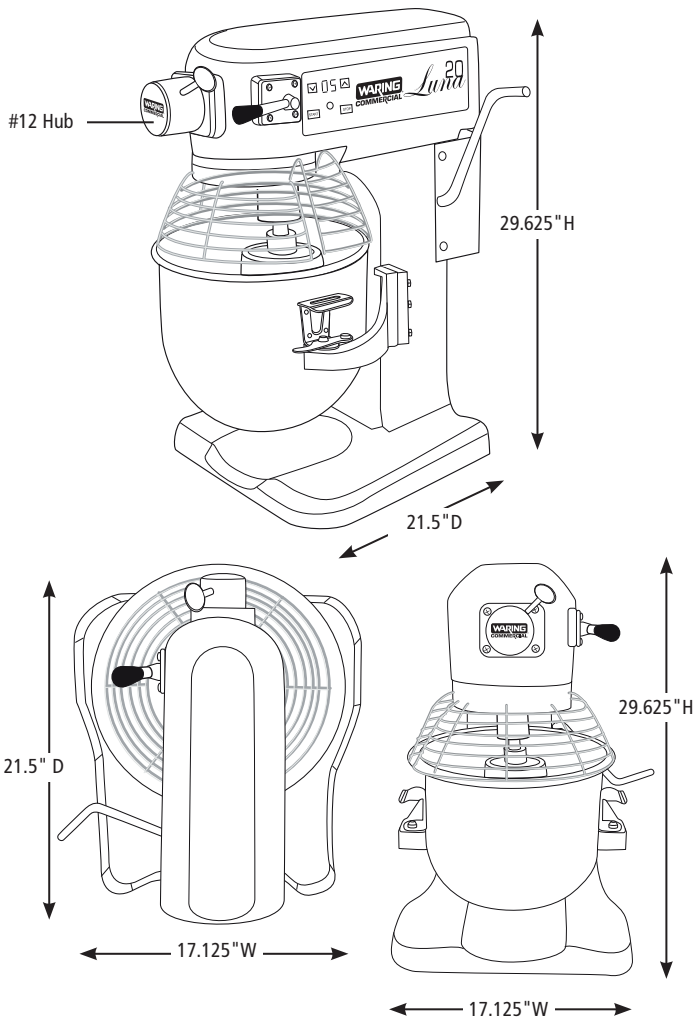

Out of Box Weight: 203 lb.

ORDERING INFORMATION	#STD. PKG.	BOX WEIGHT	CUBIC FEET	BOX DIMENSIONS D X W X H	UPC	CASE PKG.	MC WEIGHT	MC DIMENSIONS D X W X H	MBC
WSM20LT – 20-Quart Planetary Mixer with Integrated Digital Timer	1	229 lb.	11	24.625" x 21.5" x 36"	040072104176	1	229 lb.	24.625" x 21.5" x 36"	10040072104173



@waringproducts

©2024 Waring
314 Ella T. Grasso Avenue, Torrington, CT 06790
Tel. 800-492-7464 • Fax 860-496-9008

waring.com

24WC93434/ REV 08/24