



CAUTION: DO NOT IMMERSE IN WATER.
WARNING: TO PREVENT ELECTRIC SHOCK,
UNPLUG BEFORE CLEANING.

COMMERCIAL USE ONLY
 SERIAL:

↑
 Date Code Location
 YY|MM|DD
 year|year|month|month|day|day



Four 1 1/8" Toast Slots 208 Volt Toaster
WCT805B

IMPORTANT NOTICE
WCT805B and WCT815B Toasters must be connected
 to a dedicated 208 Volt circuit to ensure proper functioning.

NOTE: First toast cycle will take 4 minutes.

027400 REV00

Unit Information
 Amps 13 • Watts 2700
 Toast up to 380 slices per hour

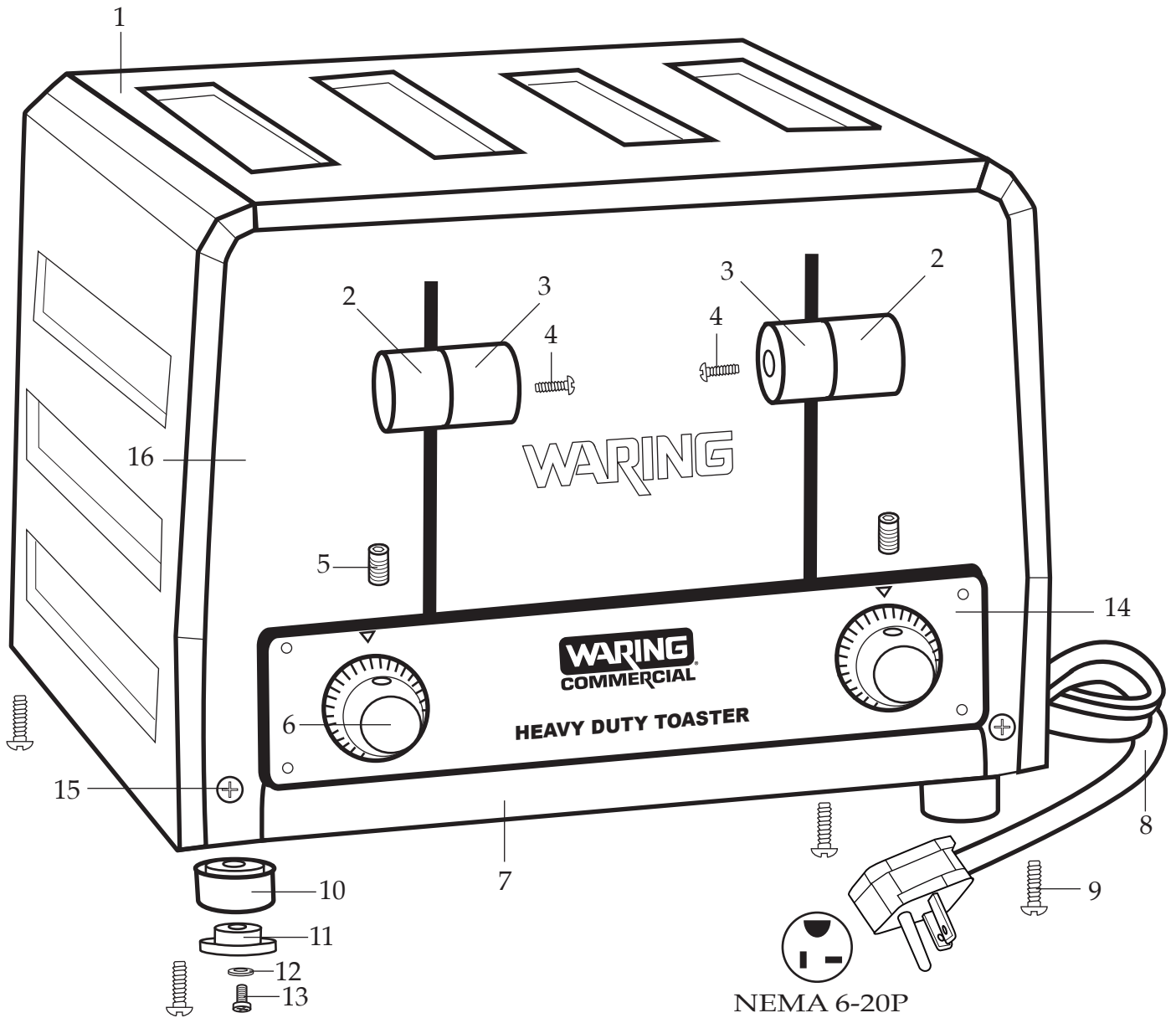

WARING COMMERCIAL

Unit Components WCT805B

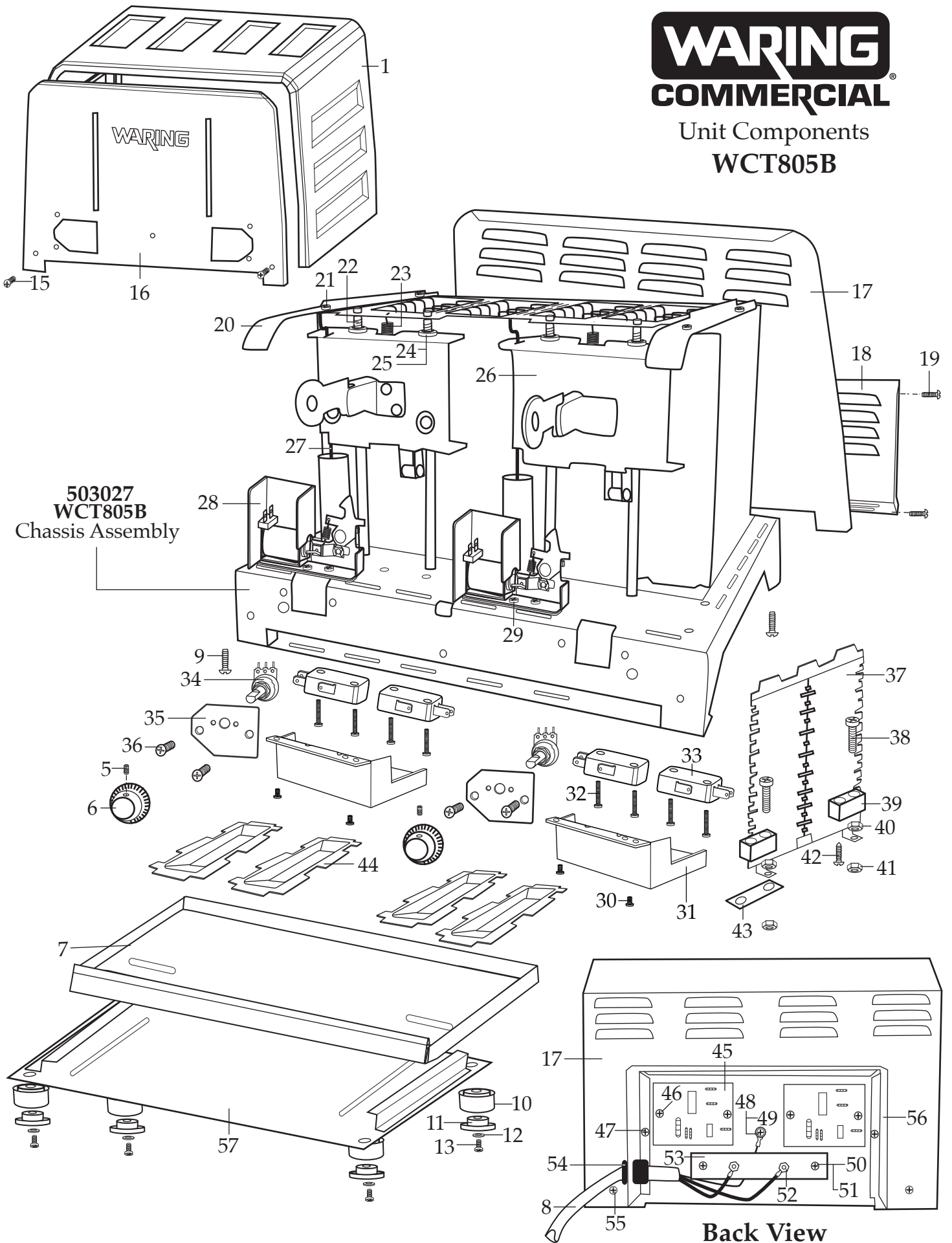

Illustration #	Part #	Description
1	027219	Top Cover Plate
2	027170	Push Knob (flat outer center 2 required)
3	027171	Push Knob (screw hole in outer center 2 required)
4	027172	Screw (2 required)
5	027173	Set Screw (2 required)
6	027174	Browning Control Knob
7	027175	Crumb Tray
8	033463	Cord Set
9	027177	Screw (4 required)
10	027178	Foot (4 required)
11	027179	Rubber Foot (4 required)
12	027180	Washer (4 required)
13	027181	Screw (4 required)
14	502939	Front Panel Assembly
15	027177	Screw (2 required)
16	027182	Front Cover Plate
17	027183	Back Cover Plate
18	027184	Power Box Cover
19	027177	Screw (4 required)
20	027185	Housing Support (2 required)
21	027186	Screw (4 required)
22	027187	Compression Wire Spring (4 required)
23	027188	Moving Bracket Spring (2 required)
24	027189	Bracket Bushing (8 required)
25	027190	C Ring (4 required)
26	502940	Moving Bracket Assembly (2 required)
27	027191	Damper Cylinder Rod (2 required)
28	027192	Locking Mechanism
29	027193	Screw (4 required)
30	034768	Screw (4 required)
31	034767	Switch Cover (2 required)
32	034769	Screw (8 required)
33	033456	Micro Switch (4 required)
34	027198	Rheostat (2 required)
35	027199	Insulated Bracket Plate (2 required)
36	027200	Screw (4 required)

Illustration #	Part #	Description
37	027902	Elements 17-7270 (8 required)
38	027202	Screw (16 required)
39	027203	Ceramic Insulator Bracket (16 required)
40	027204	Hex Nut (16 required)
41	027205	Hex Nut (16 required)
42	027206	Screw (16 required)
43	027207	Jumper Bracket
44	027947	Standard Slot Baffle
45	027943	PC Board (2 required)
46	027209	Screw (4 required)
47	027210	Screw (2 required)
48	027211	Ground Lock Washer
49	027212	Green Ground Screw
50	027213	Screw (2 required)
51	027214	Power PCB Holder (2 required)
52	027215	Hex Nut (4 required)
53	027216	Power Terminal Board
54	027224	Strain Relief
55	027177	Screw (2 required)
56	027218	Power Box Body
57	027225	Bottom Cover

Items Not Shown

- 027214**
PC Board Main PCB Holder (4 required)
- 027222**
Front Panel Assembly Screw (5 required)

Parts No Longer Used

