

Unit Information

120 volt – 60Hz – 13 Amps

Limited 2 Year Motor Warranty
 Limited 2 Year Parts and Labor Warranty

WARING COMMERCIAL Torq 2.0 Blender

with Electronic Keypad, Timer
 & 48 oz. Stainless Steel
 Container
TBB160S4

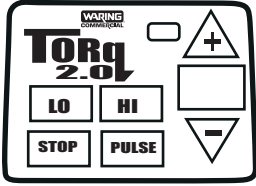

035236

Control Panel Overlay

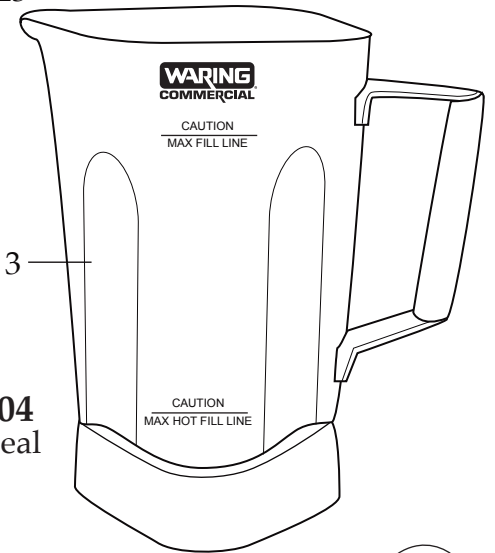
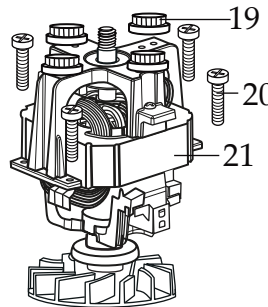
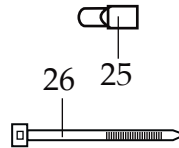
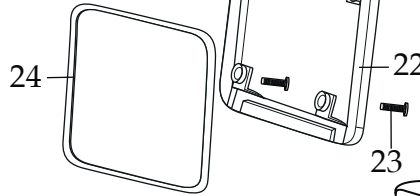
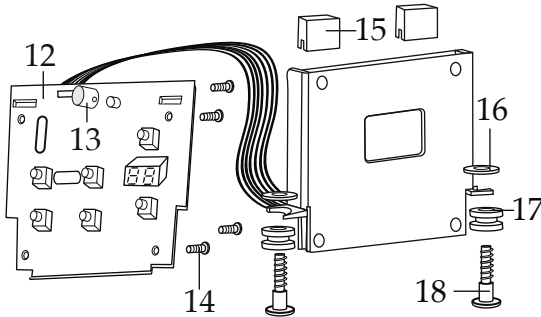
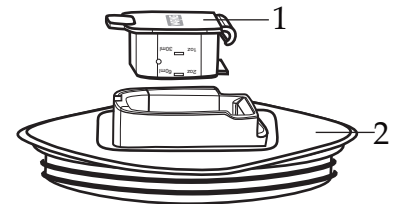
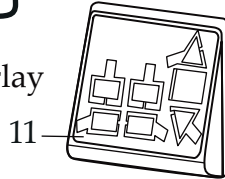
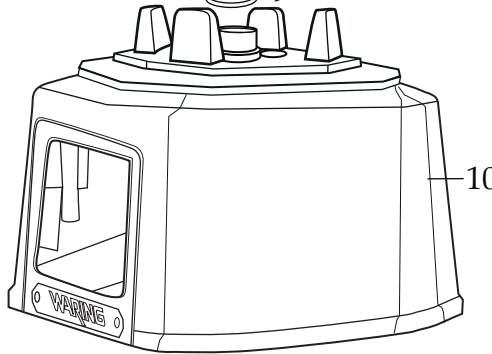
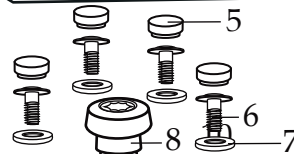
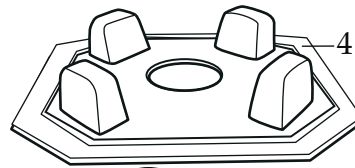

013304
 NSF Seal

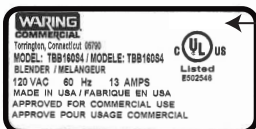
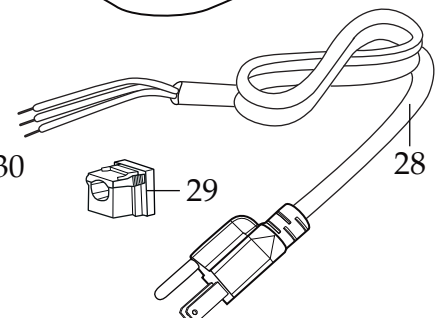
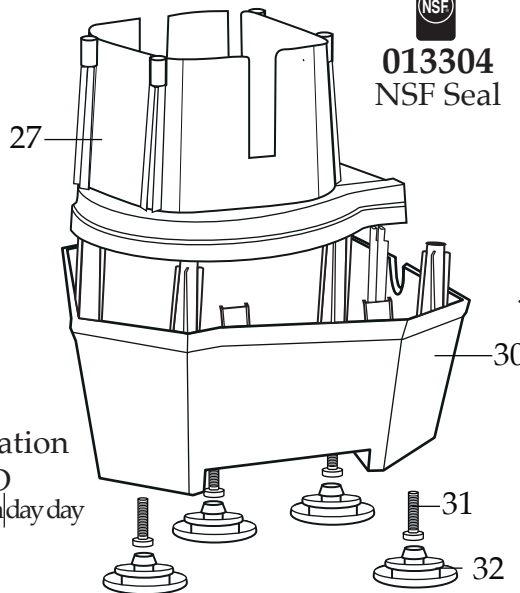

Date Code Location
 YY|MM|DD
 year year | month month | day day



Illustration#	Part#	Description
1	035153	Eastman Jar Lid Cover
2	036319-V	Vinyl Jar Cover
3	036320	48 oz. Stainless Steel Container ONLY
	503515	48 oz. Stainless Steel Container Complete with Blending Assembly
4	035885	Jar Pad
5	035085	Hole Plug (4 required)
6	034275	Sems (4 required)
7	034273	B Gasket (4 required)
8	037034	Drive Coupling Machined 2 Gen. <i>(on units after 11/15/2019)</i>
	035251	Drive Coupling
9	037033	Coupling Washer <i>(on units after 11/15/2019)</i>
10	503609	Top Housing with Badge <i>(on units after 9/28/2022)</i>
	503460-160	Top Housing Assembly
11	035234	Control Housing Front Bezel <i>(on units after 9/28/2022)</i>
12	037012	Control Panel <i>(on units after 1/17/2022)</i>
	035162	Control Panel Assembly
13	035253	LED Lens
14	035090	Screw (4 required)
15	034900	PCB Cushion (2 required)
16	013604	Washer (2 required)
17	034904	Rubber Grommet (2 required)
18	034902	Sems (2 required)
19	034272	A Gasket (4 required)
20	034274	Screw (4 required)
21	035815	Chiphua Motor with Sensor <i>(on units after 6/4/2021)</i>
	034276	ECM Motor / KB500
22	035237	Control Housing Back Bezel <i>(on units after 9/28/2022)</i>
23	035090	Screw (4 required)
24	038576	Top Housing Control Seal <i>(on units after 9/28/2022)</i>
25	012409	Small Crimp Connectors (2 required)
	019123	Large Crimp Connector (2 required)
26	013731	Cable Ties (6 required)
27	503483	Motor Housing with Dampeners
28	035124	Cordset

Illustration#	Part#	Description
29	033619	Strain Relief
30	035079 503480	Bottom Housing Bottom Housing with Feet Assembly
31	034274	Screw (4 required)
32	035088	Foot (4 required)

Wiring Diagram

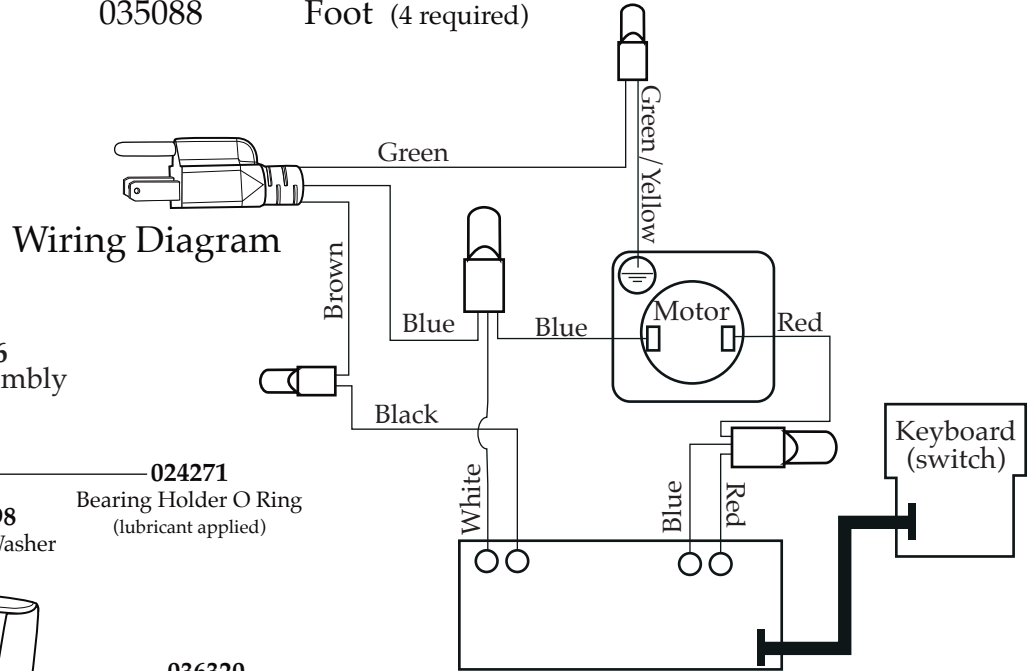

Part No Longer Used
(last used 5/6/2019)

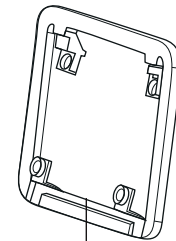

035237

Control Housing Back Bezel

Notes:

Torque 100-125 in./lbs

Sealant applied all around indicated areas.
Dow Corning Sealant RTV 733

Lubricant applied to O Ring
Dow Corning 200 (R) Fluid

