

# WARING COMMERCIAL®

Heavy-Duty 10-LB Deep Fryer

**WDF1000** / 120 volt

**WDF1000B** / 208 volt

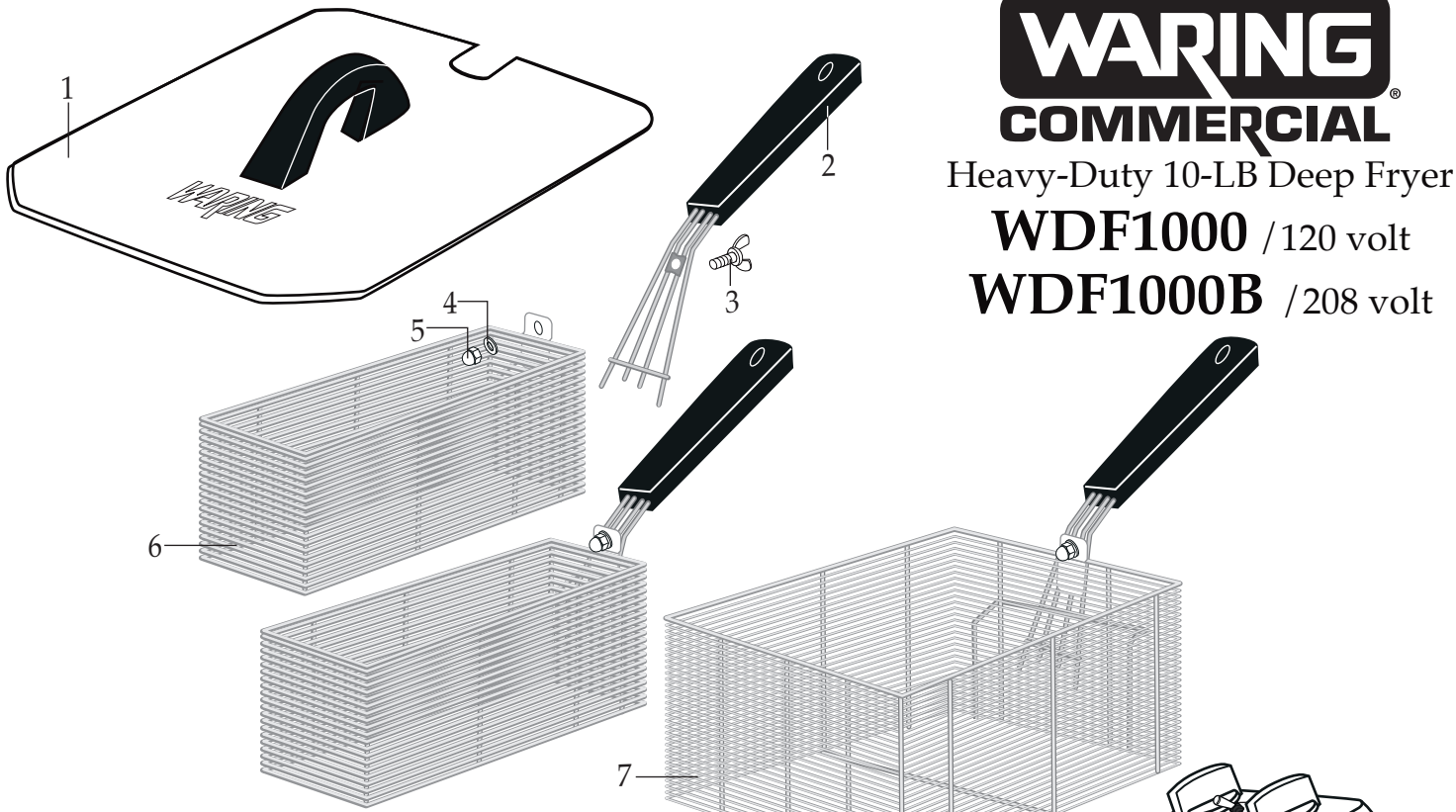

**032605**

Small Frying Basket Complete  
with Handle (TFB10)

**032601**

Large Frying Basket Complete  
with Handle (LFB10)

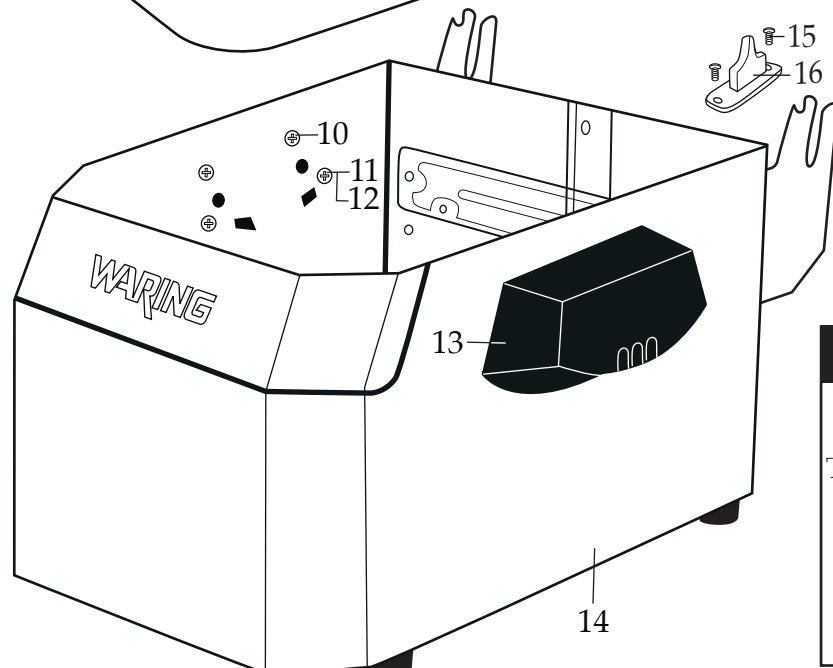
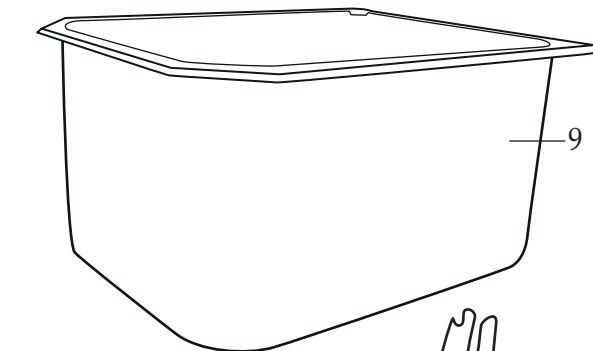

Date Code Location  
YY|MM|DD  
year year | month month | day day

YY MM DD



## Unit Information

1800 watts - WDF1000  
2700 watts - WDF1000B

Temperature Control up to 390° F

30 Minute Timer

3 Baskets – 1 large - 2 small



WDF1000



WDF1000B

## Catalog/Model

WDF1000  
WDF1000B

**WARING**  
**COMMERCIAL**  
314 Ella T. Grasso Ave.  
Torrington, CT 06790  
Tele. 1-800-269-6640  
Fax 860-496-9017  
[www.waringcommercialproducts.com](http://www.waringcommercialproducts.com)

Illustration#	Part#	Description
1	030308	Night Cover
2	030302	Basket Handle (3 required)
3	030305	Wing Nut Screw / 1 per handle
4	030303	Washer / 1 per handle
5	030304	Cap Nut / 1 per handle
6	030300	Basket-ONLY / small (2 required)
7	030301	Basket-ONLY / large
8	030306 030307	Heating Element-WDF1000 / with heat diffuser and heater stand Heating Element-WDF1000B / with heat diffuser and heater stand
9	030309	Oil Container
10	030312	Screw / 2 per body handle (2 required)
11	030314	Washer / 2 per body handle (2 required)
12	030313	Screw / 2 per body handle (2 required)
13	030311	Body Handle (2 required)
14	030310	Body Assembly / with handles and feet
15	030439	Screw (2 required)
16	030438	Safety Switch Acuator