

WARING COMMERCIAL

~~PRESS~~ WSC300

Unit Information

1800 Watts - 120 volt - 60Hz
Triple coated nonstick plates
Temp Controls 125°F - 425°F
(52°C - 218°C)
2 Year Warranty

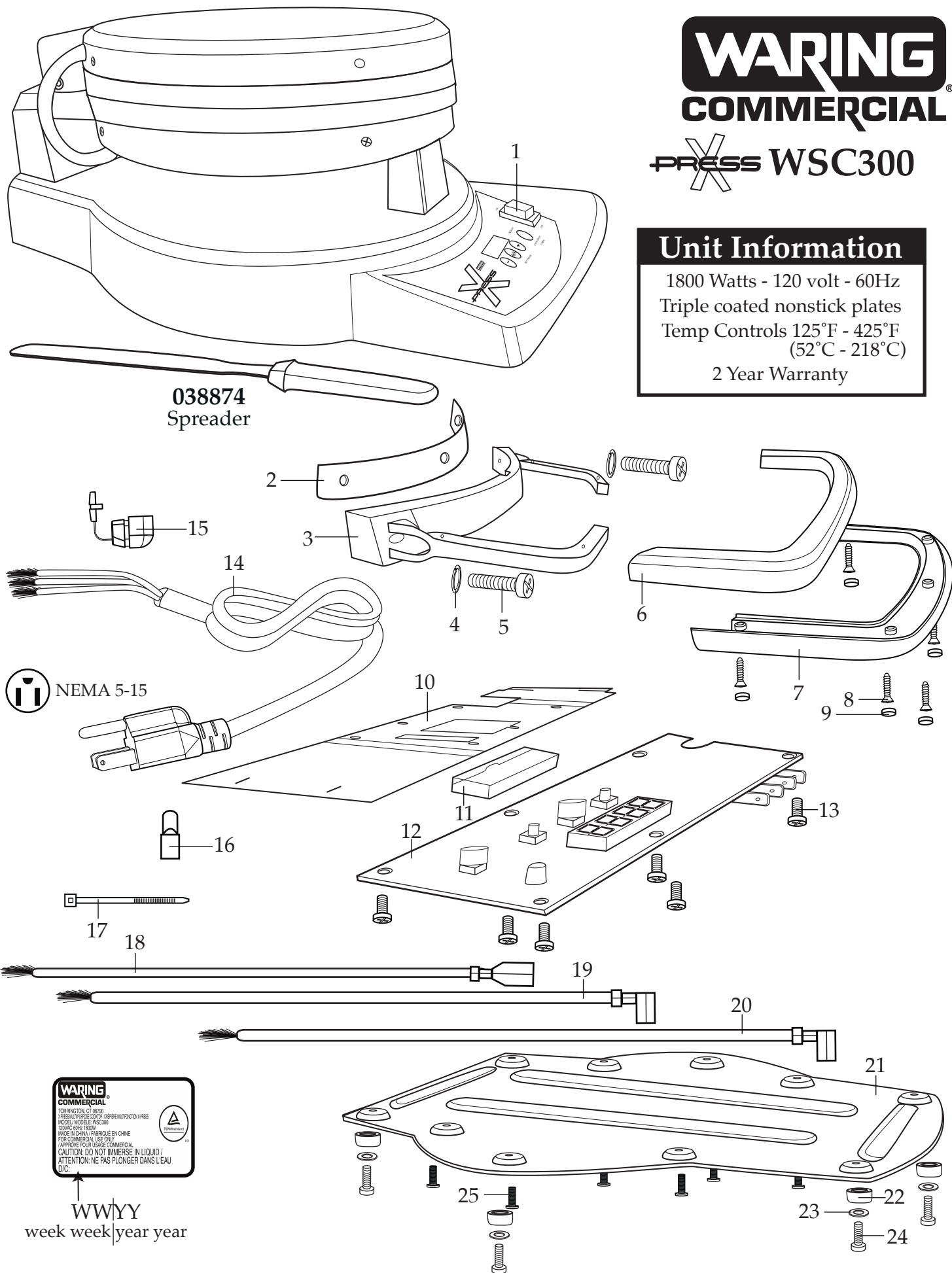

038874
Spreader

NEMA 5-15

**WARING
COMMERCIAL**
TORRINGTON, CT 06790
1000 WASHINGTON STREET, TORRINGTON, CT 06790
MODEL: WSC300
©2014 WARING COMMERCIAL
MADE IN CHINA / FABRIQUE EN CHINE
FOR COMMERCIAL USE ONLY
APPROVE POUR USAGE COMMERCIAL
CAUTION: DO NOT IMMERSE IN LIQUID /
ATTENTION: NE PAS PLONGER DANS L'EAU
D'IC.

WWYY
week week | year year

Illustration #	Part #	Description
1	038876	Rocker Switch
2	038877	Handle Insulation
3	038878	Handle Bracket
4	029993	Spring Washer (2 required)
5	038879	Screw (2 required)
6	038880	Top Handle Cover
7	038881	Bottom Handle Cover
8	037970	Screw (5 required)
9	038882	Hole Plug (5 required)
10	038883	Shield
11	038884	Timer Cover
12	038885	Power Board
13	032359	Screw (6 required)
14	038875	Cord
15	032361	Strain Relief
16	012409	Small Crimp Connector (4 required)
	019123	Large Crimp Connector (2 required)
17	013731	Cable Ties (8 required)
18	038887	17.75" Blue Lead
19	038888	19.75" Blue Lead
20	003889	20.25" Red Lead
21	038891	Bottom Plate
22	032353	Foot (4 required)
23	032354	Washer (4 required)
24	032355	Screw (4 required)
25	032750	Screw (6 required)