



# MX1050TX

## Hi-Power Electronic Touchpad Blender with 64 oz. BPA-Free Copolyester Container



\*Made in USA with US and foreign parts.

### ELECTRICAL

Voltage: 120V

Frequency: 60Hz

Watts: 1560W

Amps: 12.5A

Plug Type: NEMA 5-15P

Cord Length: 6 feet



### MAIN FEATURES

- Heavy-duty, high-performance 3½ peak HP motor with 2 speed selections is the strongest in its class. It powers through the toughest ice and frozen fruit mixtures in seconds.
- Super-high 30,000+ RPM motor speed for the smoothest consistencies.
- Electronic keypad with HIGH, LOW, OFF, and PULSE controls is simple to use and easy to clean.
- The Raptor® 64 oz. stackable, BPA-free copolyester container.
  - Ultra-aggressive blade and jar design deliver smoother consistencies and faster results.
  - Unbreakable, dishwasher-safe construction.
- High-grade, high-impact, stainless steel blade is user replaceable for easy servicing.
- Easily removable container cover with removable clear cap for adding ingredients and pressure reduction during hot food blending.
- User-replaceable, metal-on-metal, stainless steel coupling system for durability and reliability.
- One-piece, dishwasher-safe, removable jar pad.
- Optional sound enclosure easily retrofits to base for noise reduction.
- Recommended for 75+ cycles per day.
- Limited Three-Year Motor and Two-Year Parts & Labor Warranty.

### SALES FEATURES

Get smooth, consistent results every time with the Waring® MX1050TX. This heavy-duty, powerful, 3½ peak HP blender teams up with The Raptor® blade and jar assembly for maximum power and efficiency. It's ferocious enough for everything from smoothies and frozen drinks to thick spreads, desserts, dressings and all types of food preparation. This workhorse features an easy-to-clean, electronic-membrane keypad with HIGH, LOW, OFF and PULSE functions. Blend up to 75+ cycles per day. Perfect for a busy bar, health facility, school or coffee shop.

Hi-Power Electronic Touchpad Blender with 64 oz. BPA-Free Copolyester Container

MX1050TX



@waringcommercial

©2022 Waring Commercial  
 314 Ella T. Grasso Avenue, Torrington, CT 06790  
 Tel. 800-492-7464 • Fax 860-496-9008

waringcommercialproducts.com



# Hi-Power Electronic Touchpad Blender with 64 oz. BPA-Free Copolyester Container MX1050XTX

## PARTS & ACCESSORIES

- |   |  |   |  |
|---|--|---|--|
|    | <b>CAC90</b><br>64 oz. Stainless Steel Container   |    | <b>CAC95-12</b><br>64 oz. Green Copolyester Container                      |
|    | <b>CAC93X</b><br>48 oz. Copolyester Container  |    | <b>CAC95-28</b><br>64 oz. Orange Copolyester Container                     |
|    | <b>CAC93X-03</b><br>48 oz. Yellow Copolyester Container  |    | <b>CAC116</b><br>Blending Assembly Kit and Retainer Ring Kit               |
|    | <b>CAC93X-06</b><br>48 oz. Blue Copolyester Container  |    | <b>CAC119</b><br>Retainer Ring Wrench                                      |
|    | <b>CAC93X-10</b><br>48 oz. Purple Copolyester Container  |    | <b>CAC158</b><br>Blending Assembly Kit                                     |
|    | <b>CAC93X-12</b><br>48 oz. Green Copolyester Container   |    | <b>CAC159</b><br>Retainer Ring Kit   |
|   | <b>CAC93X-28</b><br>48 oz. Orange Copolyester Container  |    | <b>CAC160</b><br>Drive Coupling  |
|  | <b>CAC95</b><br>The Raptor® – Aggressive, All-Purpose, Stackable, 64 oz., BPA-Free Copolyester Container |  | <b>CAC161</b><br>Drive Coupling Removal Tool                               |
|  | <b>CAC95-03</b><br>64 oz. Yellow Copolyester Container   |  | <b>CAC169</b><br>Spatula – Custom designed for use with MX Series Blenders |
|  | <b>CAC95-06</b><br>64 oz. Blue Copolyester Container   |  | <b>SE1000</b><br>Large Sound Enclosure                                     |
|  | <b>CAC95-10</b><br>64 oz. Purple Copolyester Container   |  | <b>SE500</b><br>Small Sound Enclosure                                      |

## DIMENSIONS

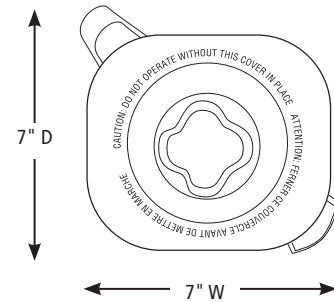
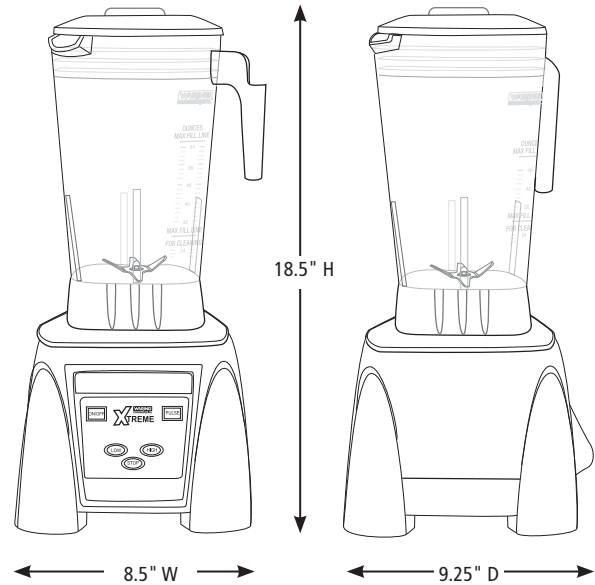

Out-of-Box Weight: 14.6 lb.

ORDERING INFORMATION	#STD. PKG.	GIFTBOX WEIGHT	CUBIC FEET	BOX DIMENSIONS D X W X H	UPC	CASE PKG.	MC WEIGHT	MC DIMENSIONS D X W X H	MBC
MX1050XTX– Hi-Power Electronic Touchpad Blender with 64 oz. BPA-Free Copolyester Container	1	16.75 lb.	1.033	11.375" x 10.125" x 15.5"	040072016981	1	17.70 lb.	11.75" x 10.75" x 16.125"	10040072016988



@waringcommercial

©2022 Waring Commercial  
314 Ella T. Grasso Avenue, Torrington, CT 06790  
Tel. 800-492-7464 • Fax 860-496-9008

waringcommercialproducts.com

22WC083132 / REV 5/22