

WARING COMMERCIAL®

3.5 Qt Sealed Batch Bowl Food Processor WFP14SW

Unit Information

6 Amps MAX
3.5 Quart Bowl
1 HP Motor
5 Yr Motor - 2 Yr Parts & Labor Warranty

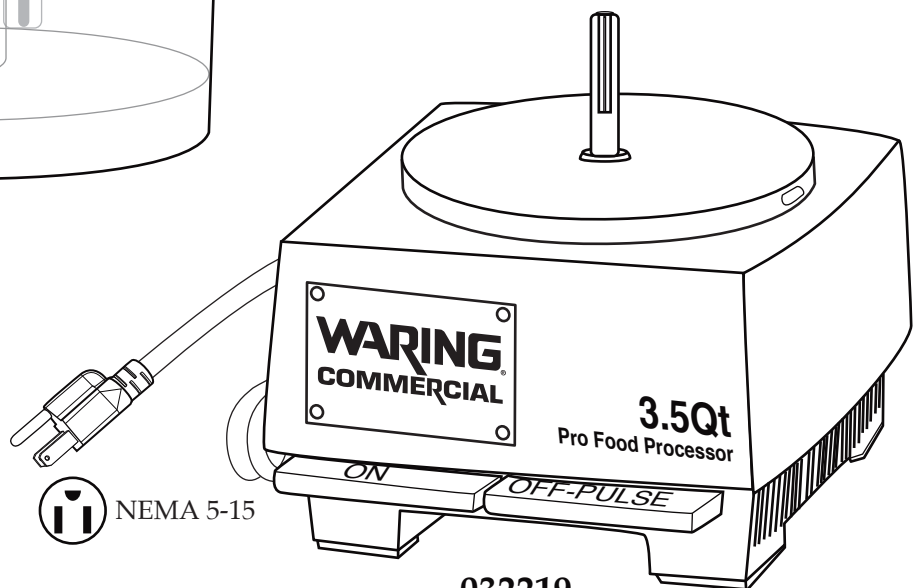
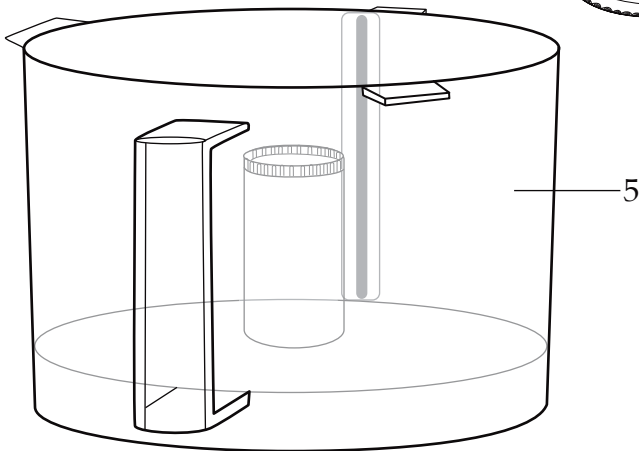
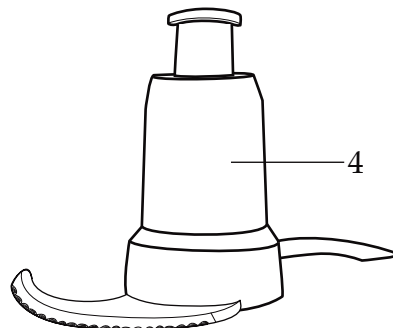
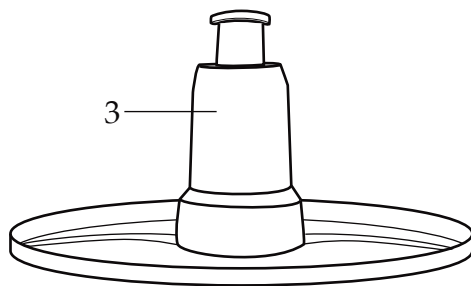
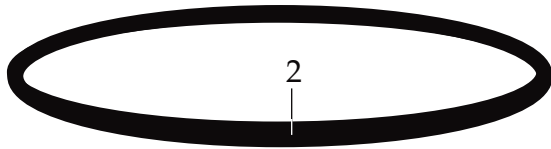
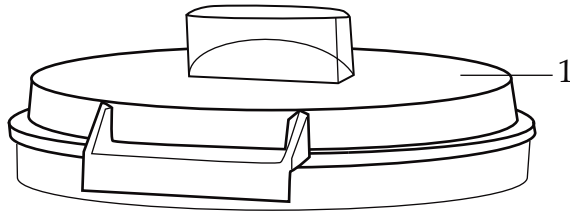

YYMMDD
↑
Date Code Location
YY|MM|DD
year|year|month|month|day|day



Illustration #	Part #	Description
1	032600	Flat Cover
2	030562	Cover Seal
3	032583	Whipping Disc
4	030568	Serrated S Blade
5	030563	Bowl

Internal Components

